



No. 234  
July  
2003

# BARC

## NEWSLETTER

### DESIGN EVOLUTION OF MAN-REM SAVING TOOLS FOR OPERATING PHWRs

**R.J. Patel and R.G. Agrawal**  
Refuelling Technology Division

#### Introduction

In the first phase of nuclear power programme, India has embarked upon installing Pressurized Heavy Water Reactors (PHWRs). Twelve units of 220 MW(e) PHWRs are in operation and a few more, including some with higher capacity of 540 MW(e), are under construction. DAE is giving thrust to harness the nuclear energy in a big way to take the present 2% contribution of national electricity production to 5% by the end of 10<sup>th</sup> plan period. Track record of the operating units are extremely satisfactory compared to international standard for achieving capacity factor beyond 85%. In each 220 MW(e) PHWR, there are 306 nos. of coolant channels. Pressure tube material for these coolant channels is zircalloy -2 / Zr-2.5 Nb. Coolant channel is the important component of Primary Heat Transport (PHT) System. Heavy Water (D<sub>2</sub>O) circulates at high pressure (100 kg/cm<sup>2</sup>) and high temperature (565°K) through PHT as coolant. Presence of radiation deteriorates the material properties. Each coolant channel has seal plug on either side to facilitate refuelling. To enhance the performance of the PHWRs, life management programme for coolant channels plays a major role. For satisfactory service life of the coolant channels, it is required to carry out periodic inspection and maintenance. In the past, techniques/tools have been used for this purpose which needs channel in dry condition. Drying of the channel involves removal of fuel, ice freezing the feeders, putting feeder blanks and draining and cleaning of the channel. This work is both time and man-rem

Contents	
1. Design evolution of man-rem saving tools for operating PHWRs ...	1
2. Data acquisition system installed .....	15
3. MoU signed between BARC and NPCIL .....	16
4. Nuclear and radio-chemistry symposium (NUCAR 2003) .....	17
5. 13 <sup>th</sup> BARC-NPCIL training workshop .....	17
6. ... ... BARC scientists honoured .....	19

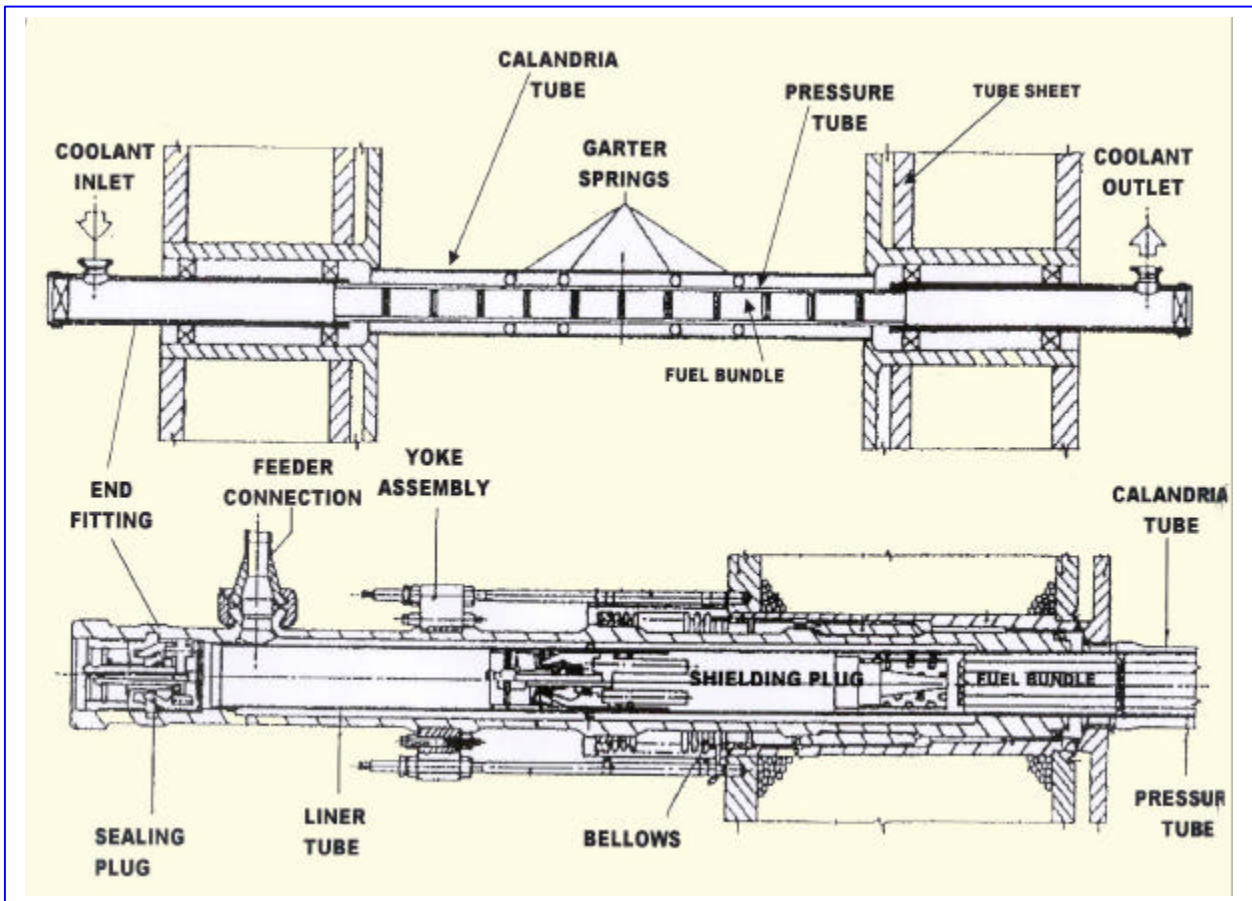

*Coolant channel assembly for 220 MWe PHWRs*

consuming. As this costs reactor down time, for economic viability of PHWRs, it is essential that this is done in minimum down time and man-rem expenditure while saving the fuel.

On-power refuelling is an important feature for PHWRs. India has the experience of doing refuelling of more than 25,000 channels. Fuelling Machine (FM) is located in the shielded FM vaults, one in each vault on either sides, of reactor calandria. These FMs get connected to the coolant channels from either side for refuelling the channel by inserting the fresh fuel from up stream end and receiving irradiated fuel in down stream end. These irradiated fuel bundles are discharged to the fuel transfer system for further transportation to the water field storage bay located outside the reactor building. Refuelling is done remotely from control room. FM works as manipulator. At Engg. Hall No.7, BARC, FM Test facilities are in operation and all FM heads for 220 MWe PHWRs have been qualified by acceptance testing at simulated

condition. This experience has helped in understanding the system thoroughly and has resulted in developing various tools/techniques using FMs for making job remotely and quickly.

For enhancing the performance of the operating PHWRs, R & D plays a major role. Quality consciousness and proper planning has reduced the reactor shutdown frequency for maintenance. An attempt is made by each operating station to minimise the planned shutdown period of reactor, for less than a month during every two years. Stations have been looking for quick and reliable tools/technique for monitoring the health of the coolant channels and maintenance tool required for attending to the problem. It is also desirable that such tools and technique should be helpful in reducing man-rem as well as fuel resulting in overall saving in time for inspection and maintenance of the unit.

Techniques like BARCIS to monitor the health of the coolant channel, technique for measuring

axial creep of coolant channels, wet scraping technique (WEST) for taking sliver samples from the inside surface of the pressure tube for hydrogen analysis and Acoustic Emission (AE) based seal plug leakage identification technique have been developed. For these techniques, existing FMs are used which makes it possible to do the job remotely and quickly. Presently, a Wet Integrated Garter Spring Repositioning System is being developed for enabling the shifting of garter spring in water filled channel to enhance the channel life.



*Fuelling Machine*

During operation, problem of excessive seal plug leakage is observed some times in operating power plants. It is required to do maintenance on the closure seal face of coolant channels. This needs reactor shut down, channel isolation and draining. An End Fitting Blanking Assembly (EFBA) has been developed which can be installed on the end fitting for temporary blockage of the leaky seal plug. During subsequent shutdown/opportunity, this assembly can be removed for repair of damage seal face. Thus, it helps to postpone the repair work. A Channel Isolation Plug (CHIP) has been developed which enables the repair of the damage seal face without draining the channel. CHIP is installed and removed by FMs.

This type of development has helped the station to carry out the inspection and maintenance

programme quickly. Use of these tools/ techniques has resulted in benefit of saving about 3300 man-rem, generating extra electricity worth about 1100 crore rupees and saving fuel worth about 100 crore rupees (see Table). Now-a-days performance of fuel handling also has been extremely good. However, use of FM for various other purpose has increased the load on fuel handling considerably. Tight shutdown programme leaves very little margin for maintenance of the fuel handling system. However, fuel-handling crews at all stations are dynamic and competent to face the challenges. Because of this, it is possible to implement these schemes.

FM handles the irradiated fuel. Both FMs work in unison for refuelling operation. In case of stuck up situations like snout-plug not removable from snout, magazine not rotating, guide sleeve/separators not withdrawing, etc., various tools like remote cutting tools, Front Openable Snout Plug and Magazine Auxiliary Drive have been developed which eliminate

the possibilities of such emergency situations with minimum man-rem expenditure.

### **Tools / Techniques Developed for 220 MW(e) PHWRs Coolant Channels**

As mentioned above, various tools / techniques have been developed, centered around existing FMs. Most of the components become a part of the PHT boundary. Hence utmost care is called for in detail design, qualification, operation and maintenance. The pressure tube size is the smallest compared to other reactors in the world. Hence, it was a challenge to meet the requirement of accommodating the components in a very limited space while maintaining the safety features. These are found to be extremely useful to operating plants in the absence of non-availability of an alternative system.

**Table : SAVINGS IN MAN REM EXPENDITURE, FUEL AND COST IN OPERATING PHWRs DUE TO USE OF MAN REM SAVING TOOLS/TECHNIQUES**

Sr. No.	Tool/ Scheme	Unit	Number of channels in which tools/techniques used	Manrem consumed	Manrem saved (compared to other tools for the same job)	Reactor shut down time saved (in days)	Gain in electricity generation due to saving in time (Rs. in crore)	Saving of number of fuel bundles	Fuel cost saved (Rs. in crore)	Total saving (Rs. in crores)
1	TMAC tool	All operating PHWRs (12 Units)	Reactor creep measurement done for 70 times in all operating units(done during every annual shut down)	266.0	280.0	210	201.60	NA	---	201.60
2	BARCIS Seal Plug	RAPS 1&2	323	67.0	1292.0	323	310.08	3876	38.76	348.84
		MAPS 1&2	340	68.0	1360.0	340	326.40	4080	40.80	367.20
		NAPS 1&2	21	4.0	84.0	21	21.16	252	2.52	23.68
		KAPS 1&2	17	16.7	68.0	17	16.32	204	2.04	18.36
3	Wet Scraping tool	RAPS 1&2	87	15.0	174.0	100	96.00	1044	10.44	106.44
		MAPS 1&2	9	4.5	18.0	10	9.60	108	1.08	10.68
4	Channel Isolation Plug	RAPS 1&2	1	1.8	4.0	1	0.96	12	0.12	1.08
		NAPS 1 & 2	5	1.5	3.0	5	4.80	60	0.60	5.40
		KAPS 1 & 2	1	3.2	3.0	1	0.96	12	0.12	1.08
5	End fitting blanking assembly	RAPS 1 & 2	8	0.5	0.5	8	7.68	NA	-	7.68
		NAPS 1&2	6	0.5	0.5	6	5.76	NA	-	5.76
		KAPS 1&2	3	0.2	0.2	3	2.88	NA	-	2.88
		KAIGA 1&2	1	0.1	1.0	1	0.96	NA	-	0.96
		<b>TOTAL</b>		<b>449.0</b>	<b>3288.2</b>	<b>1046</b>	<b>1005.16</b>	<b>9648</b>	<b>96.48</b>	<b>1101.64</b>

Note: 1. Data prepared based on information received from operating units of PHWRs as of December 2002

2. Costs are indicative and worked out based on average cost of energy as Rs. 2/unit and fuel average cost as Rs. one lakh / fuel bundle

### ***Axial Creep Measurement of coolant channels***

Axial Creep Measurement is required to be done in every annual shutdown of the plant. Earlier, optical instrument was used to measure the creep manually. This was time consuming and it was difficult to adopt this scheme for standardised design of new reactors. Hence, a technique called TMAC (Technique for Measuring Axial Creep) was developed and is in use by all operating power stations. FMs are used to do the creep measurement and a software developed for this purpose analyses the creep reading and gives data in the preferred format.

To save further time, a technique is being perfected for non-contact axial creep measurement of coolant channel. Initially, a laser sensor was used for monitoring the gap between the 'E' face and FM front face. Laser sensor was found to be very sensitive to the foreign particles on the 'E' face. Alternatively, an ultrasonic sensor has been used which is found to be suitable. A tool is developed which can hold the sensor in the FM. A software has been developed for acquisition and processing of the data and to give creep value in lattice shape of the reactor. The scheme has been tried in one of the units on an experimental basis. Further refinement is in progress.

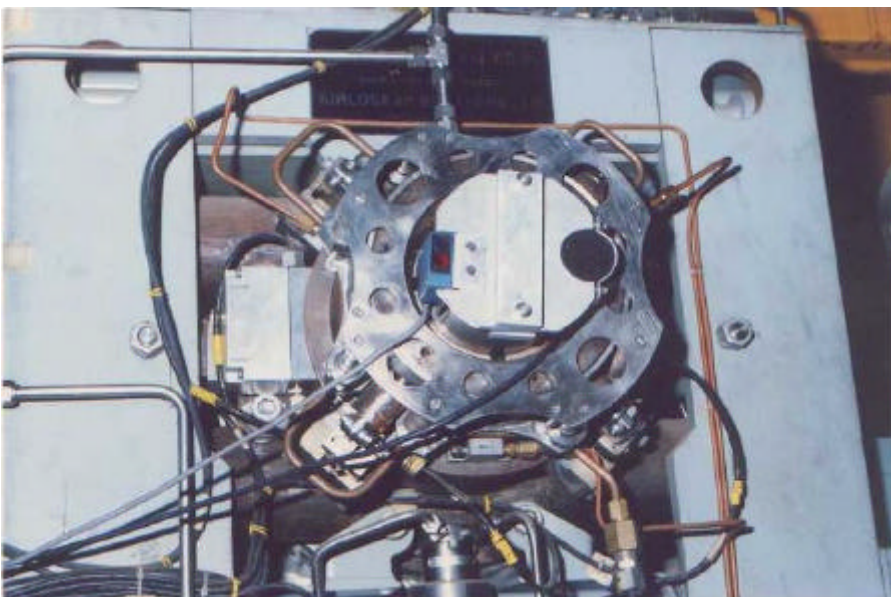

*Remote creep measurement of coolant channels*

### ***Special sealing plug for BARC Channel Inspection System (BARCIS)***

Periodic In-Service Inspection (ISI) of the coolant channels is carried out to monitor the health of the coolant channels in PHWRs. Initially, methods were developed at BARC for ISI of channels. In this method, it was required to drain and dry the channels for carrying out ISI. The fuel was required to be removed and discharged. The method was time and man-rem consuming. Due to this limitation, it was not possible to carry out ISI in a large number of channels.

To do the ISI quickly, it was proposed to do ISI in water filled channels. A scheme was worked out some time in 1992 for carrying out ISI in water filled channels. A concept of special sealing plug, to install inspection head remotely using FM, was worked out. The plug is having a hole of about 37mm in diameter for providing passage for drive tube. The plug is installed in the end fitting of the channel which has a bore of 83 mm which is the smallest in the world. It was a challenge to design the plug having all safety features in this small space available. A drive mechanism was suggested for driving the inspection head inside the channel. A programme was collaborated with Division of Remote Handling & Robotics (then Reactor Control Division) and Atomic Fuels Division for development of inspection technique,

drive mechanism and data acquisition system. Refuelling Technology Division was responsible for development of special sealing plug, associated service tools, fuel-handling procedures for doing ISI and an in-head calibration plug. The scheme was named as BARC Channel Inspection System (BARCIS) and is in use at all stations. The scheme is much simpler than the

equipment purchased by NPCIL for the same purpose.



Special seal plug (Mark IV) for BARCIS

The special seal plug enables one to install the inspection head remotely in the channel, to be inspected by FM and also allows the entry of drive tube to be connected to inspection head for transferring the collected data by inspection head to outside. Thus, special seal plug plays a major role in ISI operation. Different versions of plug have been evolved and used for ISI of 700 channels in 220 MW (e) PHWRs.

Recently, Mark IV design has been developed with advance features for better reliability and safety. This plug has spider and jaw mechanism in safety latch for increased strength and use of a

plunger sleeve to safeguard the movement of plunger in case of excessive differential pressure from FM side. This design is matured, sturdy, operator friendly and saves further man-rem expenditure and time. Maintenance frequency required is also less. MK-IV design of the plug has been recently used for the first time for 35 channels of ISI at MAPS successfully.



In-head calibration plug

An in-head calibration plug has been developed for on-line calibration of the sensor of BARCIS inspection head. This plug is held in opposite FM. It has got special mechanism to have firm orientation and a pressure tube spool piece having standard NDT calibration notches.

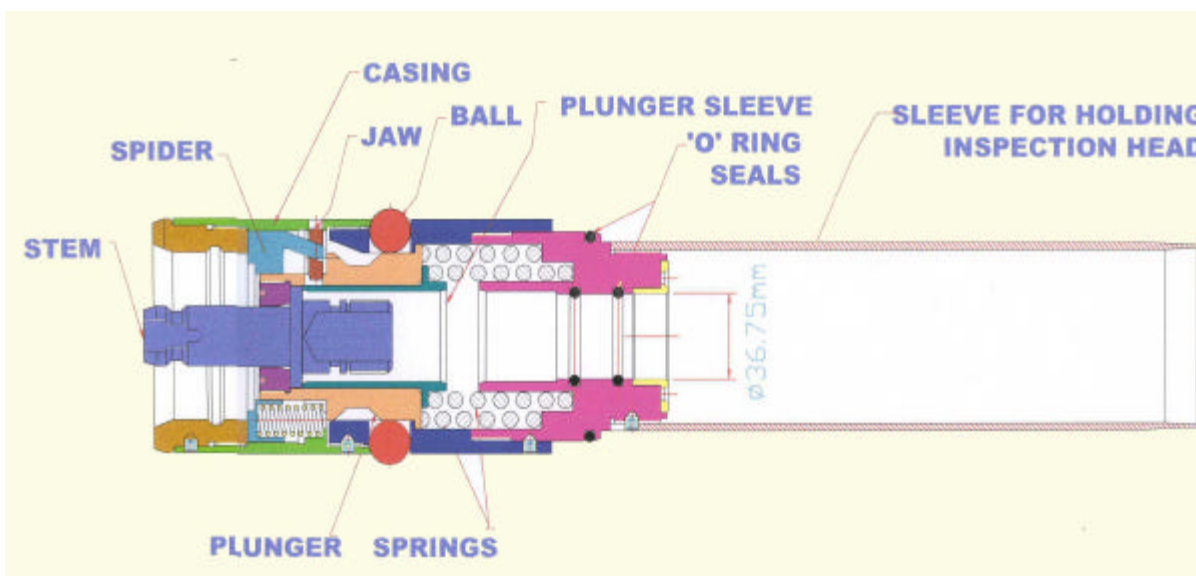

Special seal plug (Mark IV) for BARCIS

The fuel handling procedure has been written such that in no case fuel bundles can be left in channel before taking up inspection and it confirm that no inventory is left in the channel before boxing up the channel. The necessary service tools to enable operation and maintenance of the plug also have been developed. Detailed operation and maintenance manual as well as specification for manufacturing of special sealing plug have also been prepared. Memorandum of Understanding has been signed between BARC and NPCIL to transfer the special sealing plug technology to NPCIL. The design drawings of special sealing plugs along with operation and maintenance manual and specification for manufacturing of special sealing plugs have been handed over to NPCIL.

### ***WEt Scraping Tool (WEST)***

Hydrogen concentration is an important parameter that must be assessed to evaluate the fitness for service of pressure tubes. Assessing hydrogen content means removal of a pressure tube. This is very costly because of the length of the shut down required, and yields information on one reactor lattice location only. In recognition of the need for a better approach, a tool was developed by Reactor Engineering Division for taking sliver sample of material from the inside of a pressure tube. This tool has a limitation, as it requires channel in dry and cleaned condition. Accessories such as high pressure hose and tubing along with pump is required. This was a manual operation and was time consuming.

To increase the productivity, to minimise man-rem expenditure and reactor shut down time, a scheme was worked out to take the sliver samples from water filled channels using FMs. The existing scraping mechanism of dry scraping

tool was retained and additional features like miniature, special bearings for self orientation at 12 O'clock position, compatibility with fuel, provision of a piston to transmit the FM ram force and motion to the carriage of the tool, etc. were added. The tool has oxide tool bit cutter to remove oxide layer of about 100 micron depth and subsequently, the metal tool bit cutter makes a sliver cut of about 150 micron. The weight of the sample is 60-120 mg. The technique was named as WEt Scraping Tool (WEST). 'C' Ram force of FM is applied to move the carriage at desired speed for taking proper sliver cut. Three numbers of WEST tools are used to enable three sliver samples to be moved from three axial locations from each channel in a single visit of FM.



*WEt Scraping Tool (WEST)*

By using WEST extensions, two pairs of fuel bundles are discharged to the other FM, leaving eight bundles in the channel. As per detailed procedure, the scraping tool is positioned to the desired location in the channel by using B-ram and WEST extensions. In-board end of the tool is supported against the fuel column held by C-ram of opposite FM. C-ram of scraping FM is advanced at controlled force for moving the carriage to take the sliver cut. The total C-ram movement is 130mm. The procedure takes care that tool does not drift during scraping operation. As the tool takes support against fuel bundles, design takes care to ensure the adequate flow for the bundle cooling.

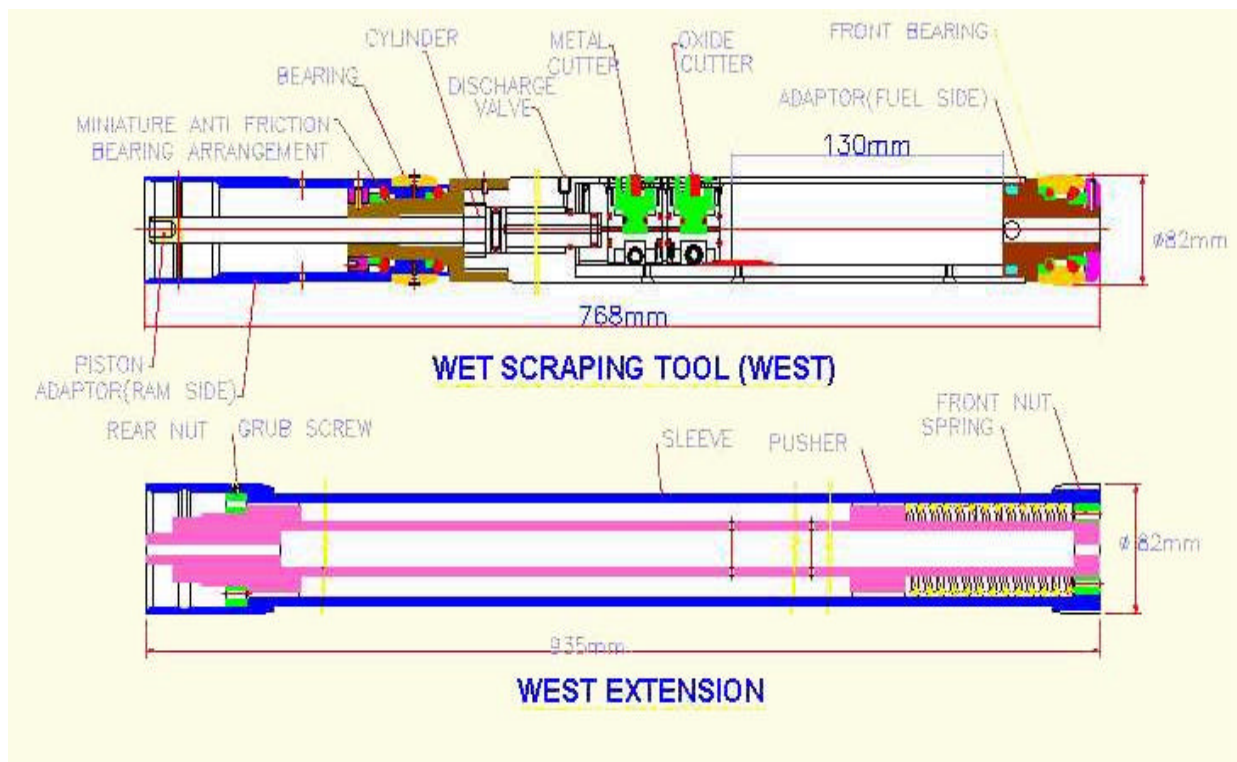

*Wet Scraping Tool (WEST) and WEST extension*

These samples are collected manually and after visual examination and weight measurement, they are packed in shielding flask for chemical analysis at BARC. The entire scraping operation of one channel can be completed in about 4-5 hours. The procedures are well laid out and site personnel have been trained to do the job independently. This tool has become the standard for taking sliver samples. WEST has been successfully used for scraping 9 channels in MAPS-1 and 87 channels in RAPS-1.

### ***Leaky seal plug identification by using Acoustic Emission Technique***

After installation of seal plug, FM ensures that leakage is within acceptable limit of 20 gms/min. After some time, this leakage is expected to reduce to less than 10 gms/day. However, subsequent monitoring of seal plug leakage is not done. Considering 612 nos. of seal plugs in each unit, it is highly important to develop a system to routinely monitor the leakage of D<sub>2</sub>O from seal plugs. This contributes greatly for keeping a control on D<sub>2</sub>O loss and associated rise in tritium activity. For this purpose, an acoustic emission based leakage monitoring system has been developed in collaboration with Atomic Fuels Division and Control Instrumentation Division. The leakage through seal defect gives rise to acoustic signal, which is picked up by an acoustic sensor and the signal is processed to assess the leakage. A tool mounted with sensors is held by FM. FM takes this tool to reactor face and contact is established for monitoring the signal. To isolate the FM side



*Sliver sample taken by WEST from pressure tube*



noise, the tool is designed to insulate the sensor from FM side noise.

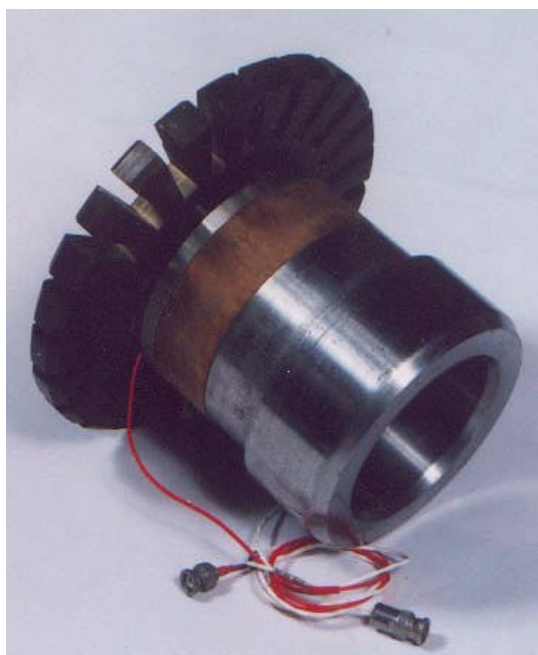

*Acoustic emission tool*

The data acquisition and analysis system is kept in accessible area. While maintaining PHT in hot shutdown condition or reactor in operation, both FMs holding the sensors can scan the entire reactor face in just less than two shifts. Laboratory experiments at Hall No.7 indicated that a leakage of 100 cc/hour may be possible to measure. However, considering the noise in reactor, more thrust will be to group the seal plugs depending on the range of leakage. The technique was used once in KAPS-2 and recently

in NAPS-2. The system performance is satisfactory as five numbers of plugs were detected for higher leakage. Quantification of the leakage is done based on experimental data in Hall No.7. Attempt is being made to develop the scheme for confirming the leakage from the detected leaky seal plugs. After this, technique will get fully qualified.

### ***Wet Integrated Garter spring REpositioning System (Wet INGRES)***

During operation of the reactor, need arises to shift the garter springs in coolant channels to enhance their life. INGRES tool has been developed by RED for this purpose. Use of this tool in the channel require defuelling, isolating, draining and drying of the channel for enabling INGRES operation. To make the method quick and oriented towards saving man-rem expenditure, a scheme has been proposed to use FM and associated equipment like special closure plug and Wet INGRES Delivery Equipment (WIDE) to enable the INGRES operation in water filled condition. Modifying the existing dry INGRES tool and drive system is being done by Reactor Engineering Division. This complete system is called Wet INGRES System. This system is simpler than SLARETTE equipment used in Canada which has turret type of arrangement and uses a special low pressure seal plug.

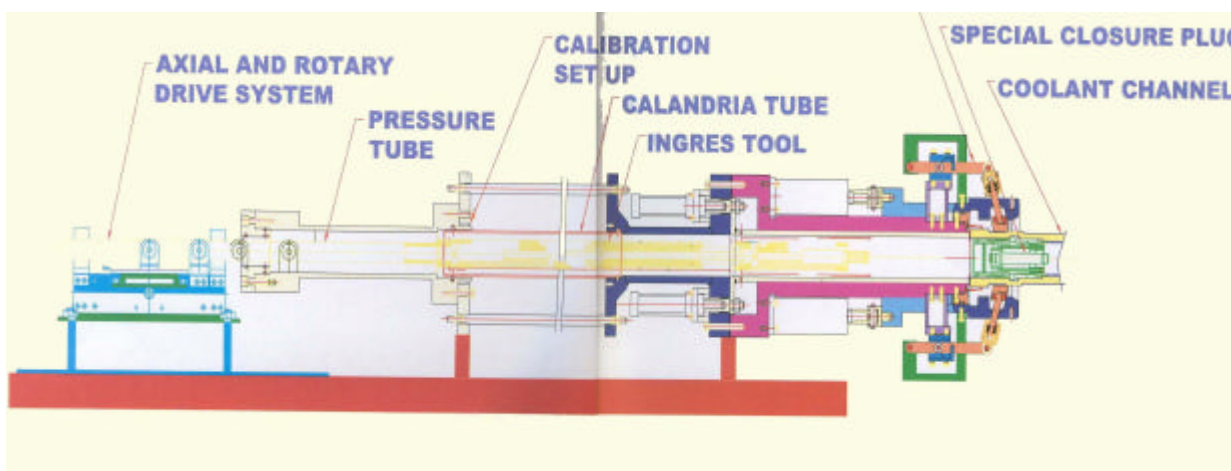

*Wet INGRES Delivery Equipment (WIDE)*

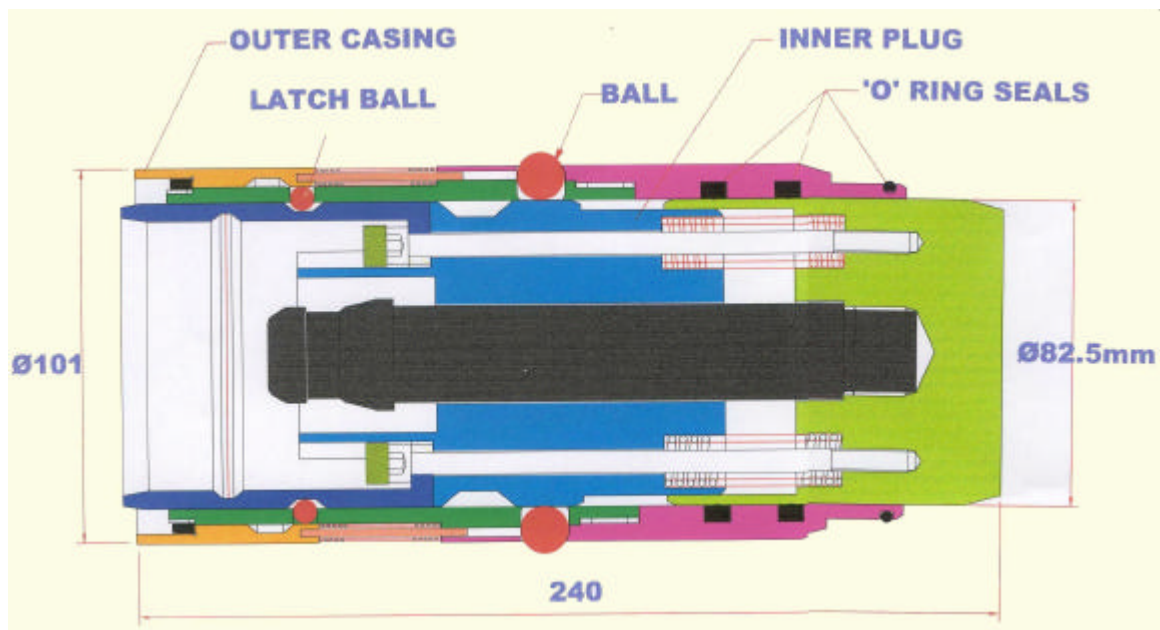

*Special closure plug for INGRES*



*Special closure plug for Wet INGRES*

The Special Closure Plug is operable by FM and gets installed in the end fitting seal plug position after defuelling the channel. The plug is made in two parts – an inner plug and an outer plug. By operation, of a mechanism, inner plug gets detached from the outer plug and moves along with INGRES tool while doing INGRES operation. Detachment of inner plug creates a bore of 82mm diameter for tool entry. After the INGRES operation, the tool is retrieved back and inner plug gets attached to the outer plug.

WIDE is developed which houses the INGRES tool, provides facility for in-situ calibration of the tool, makes leak tight connection with the end fittings, operates safety latch of the closure plug and allows the entry of drive tube. It has got hydraulic and pneumatic system for operation of various cylinders and actuators as well as to

provide filling and venting provision. WIDE (MK II) has been developed having auto clamping features.

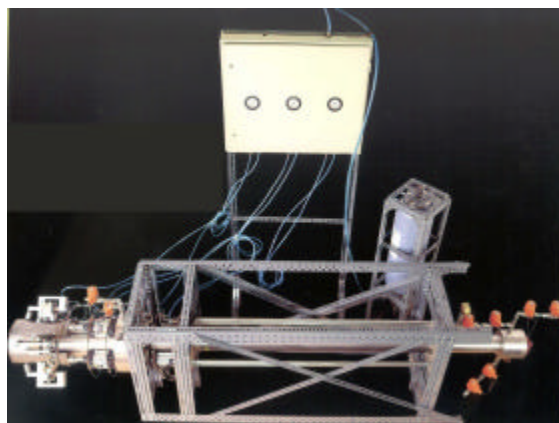

*Wet INGRES Delivery Equipment (WIDE)*

The special closure plug and WIDE have been satisfactorily tested separately. These components were assembled on test bed at Hall No.7 along with dummy INGRES tool and drive system. 10 numbers of integral trials, each in dry and wet conditions of the channels have been carried out successfully. This establishes the feasibility of using Wet INGRES in reactor. Further qualification trials are in progress.

### ***End Fitting Blanking Assembly (EFBA)***

An EFBA has been developed to block the excessive leakage from the seal plug temporarily

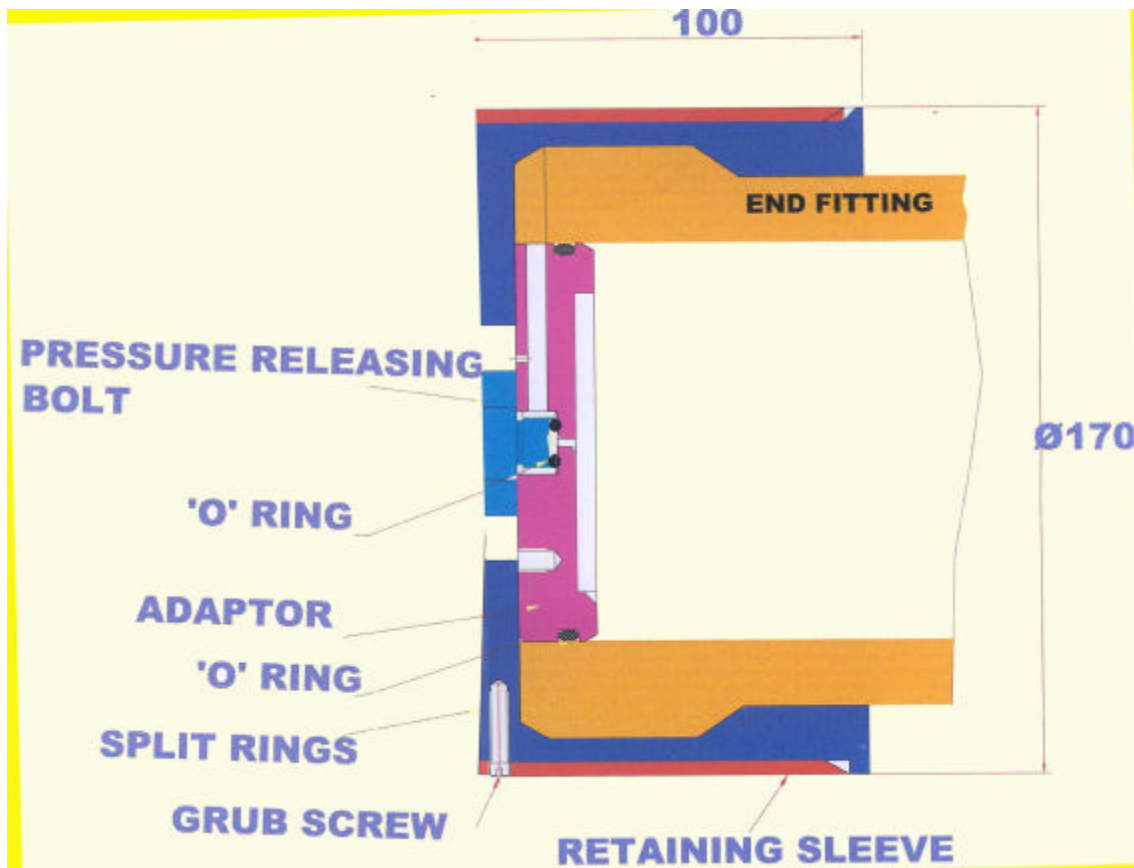

*End Fitting Blanking Assembly (EFBA)*

till the next opportunity for the repair. This works as a secondary sealing device. An 'O' ring seal is used to be located, behind the seal plug on an adaptor. This is retained by split rings and retainer sleeve. It has got the provision for releasing the pressure before removal. This has been qualified by analysis as well as experiments. The dimensions are optimised such that neighboring channels can be refuelled. Installation takes about 1 minute time. This is being used by the operating PHWRs.

### ***CHannel Isolation Plug (CHIP)***

During operation of the reactor, some time closure seal face gets damaged. Temporarily, this leakage can be blocked by using End Fitting Blanking Assembly. However, ultimately the closure seal face needs to be repaired and normalised. To enable this repair in water filled channel, a concept of Channel Isolation Plug was developed by RAPS. This helps in isolating the closure seal face and makes it accessible for

repair. CHIP design was upgraded to incorporate safety features to make it reliable for reactor use.



*CHannel Isolation Plug (CHIP)*

This plug has been supplied to almost all power stations. FM installs CHIP in the end fitting. Some of the components are removed to make the closure seal face approachable. After repair, components are installed back and CHIP is removed by FM. CHIP has two steps diameter, one similar to shield plug for getting latched in

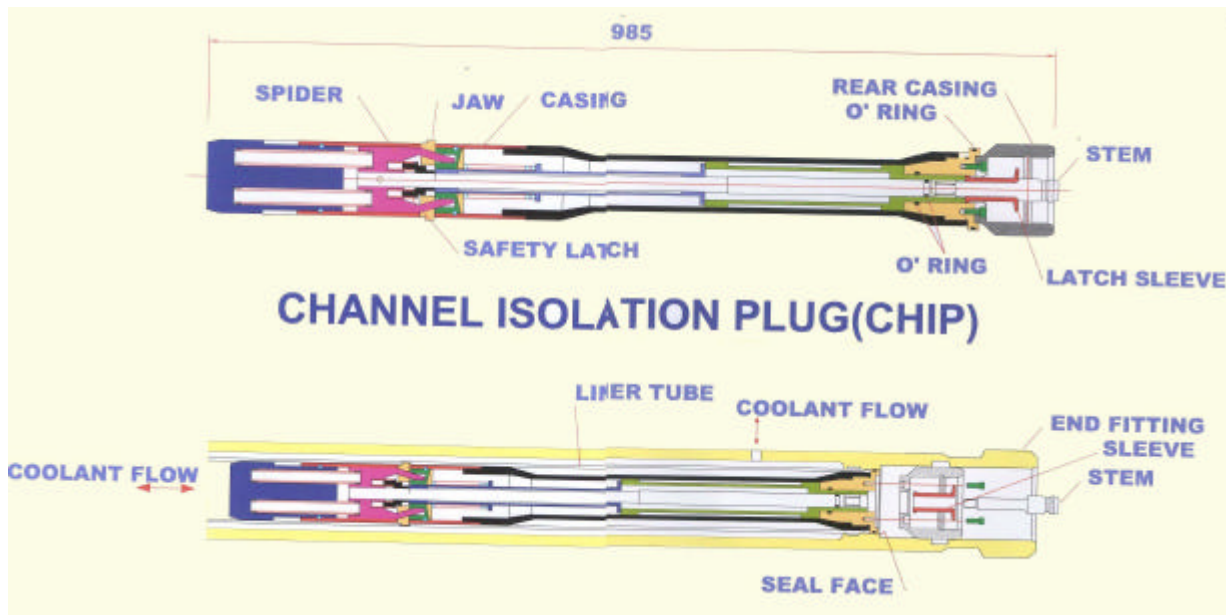

*Channel Isolation Plug (CHIP)*

the shield plug groove, and another similar to seal plug size as is to be installed in the seal plug position of end fitting. 'O' ring seals are used for sealing. Safety features have been incorporated. CHIP has become a standard tool for all operating power stations. This along with EFBA were very helpful to repair the heavily damage face in C-13 channel of KAPS-2. The job could be completed in a very short time.

### ***Pressure tube ID measurement using Three Point Micrometer***

A scheme for measuring coolant channel ID in water filled condition for 220MW(e) PHWR was evolved jointly with NPC for resolving the anomaly of apparent ballooning of pressure tube in KAPS-2. The tool was qualified and used for measuring the i.d. of channel J14 and L08 in KAPS-2 in September 2002. The measurement indicated that there is no ballooning of coolant tube.



*3 point micrometer for ID measurement of pressure tube*

### **Tools Developed for Averting / Handling Emergencies in Fuel Handling System**

The following tools/machines have been developed for averting/handling emergencies in fuel handling system.

#### ***Front Openable Snout Plug Assembly***

Snout plug boxes the FM. If snout plug gets stuck and FM rams are not able to operate from inside, then it is difficult to retrieve it from the situation. Presence of irradiated fuel bundles makes the approach to the FM difficult. One can think of cutting the snout plug remotely. However, during feasibility study, this task seems to be difficult by using conventional machine tools. Considering complexity involved in retrieval from snout plug stuck up situation, a front openable snout plug has been developed. Basically, existing snout plug mechanism is used with certain design changes to make it openable from front. After taking out the plug retainer from the plug, pulling element can be pulled by using a service tool. A prototype has been fabricated and demonstrated. Reactor worthy plug is being assembled.



Front openable snout plug

provision to isolate oil hydraulic motor was not there. Hence, if the oil motor is jammed, then it will be difficult to rotate the magazine. This design was fabricated and installed on the FM head K-6 during acceptance testing. Demonstration to rotate the magazine was held after by-passing the oil motor.

An improvised design has been worked out, fabricated and installed on the FM head KG 5 at Hall No.7. In this design, provision to disconnect the oil motor is available. By pushing a spring-loaded lever, a key gets shifted which disconnects the motor. Subsequently, pinion can

### Magazine Auxiliary Drive

In 220 MW(e) PHWR, FM does not have redundant magazine drive. If the drive fails because of motor failure or oil system failure, and if magazine is having irradiated fuel bundles, it will be difficult to retrieve from the situation. In such condition to facilitate magazine rotation from a distance behind the shielding, a magazine auxiliary drive has been designed. This is installed before speed reduction gearbox. This drive is having a gear pair in which oil motor is connected to the gear and in turn getting connected to the magazine drive. To rotate magazine, the pinion of the gearbox is manually rotated. In this design,

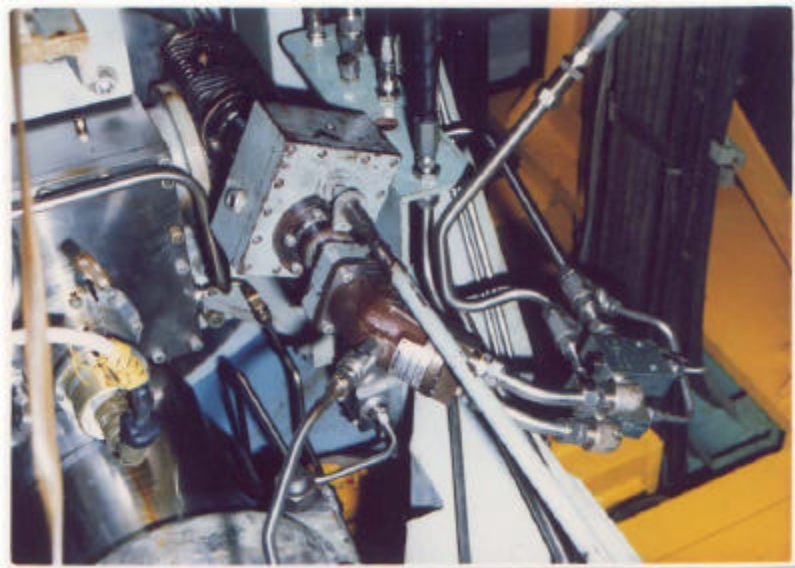

Magazine auxiliary drive installed on F.M.

be rotated for rotating the magazine. The device is under long term evaluation.

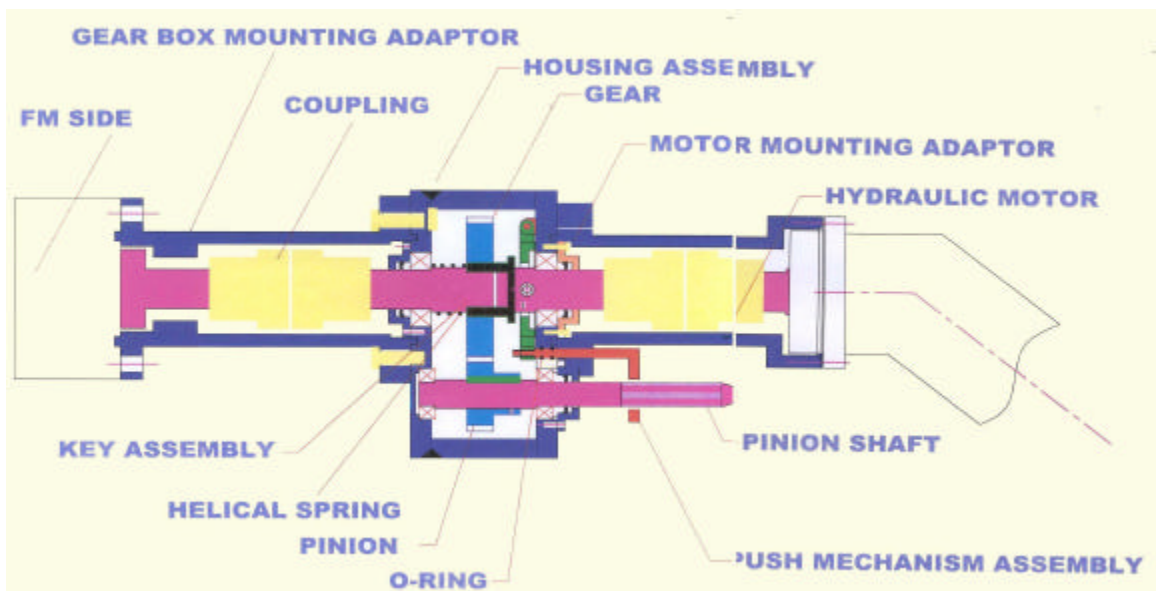

Magazine auxiliary drive installed on F.M.

### ***Development of remote cutting tools***

In PHWRs fuel handling, it is envisaged that during refuelling / fuel transfer if guide sleeve (only in case of RAPS/MAPS), separator tips and snout plug get stuck, it may result in a situation difficult to handle. To get rid of such problem, it may be required to cut this component.



*Remote cutting machine for guide sleeve*

As discussed earlier, front openable snout plug once used may not require cutting. It was proposed to develop remote cutting tools for cutting the problematic components. To utilise the expertise of Centre for Design and Manufacturing (CDM, previously CWS), the problem was explained and these machines have been developed by CDM in a well-coordinated manner. Depending on the situation, the cutting machines can cut the guide sleeve or separator tips through the coolant channels on which FM get stuck. Chips are sucked by vacuum pump from the other side. Cutting machine has been developed and demonstrated. For cutting the separator tips, a cutting tool head is being developed. This head is compatible with guide sleeve cutting machine. Availability of this machine may help to quickly come out of such emergency situation.

### **Conclusion**

Ensuring the integrity of the coolant channels, evaluating their fitness for service and extension

of life are of major concern in PHWRs. In the past, it was required to dry the channel for this work which needs substantial efforts for fuel removal, plugs removal, isolating the channel, feeder freezing and channel draining, This consumes considerable man-rem and elongates the costly shut down period. Recognising the need for developing the techniques for this purpose which can work in water filled channels, tools / techniques have been developed, centered around the existing FMs, at BARC for monitoring the health of the coolant channels and to enhance the life of the coolant channels. Most of the tools have been deployed and have become standard tools in the operating PHWRs. This is found to be of great help to the operating PHWRs for saving man-rem expenditure, fuel and minimising reactor shut down time (see table).

During implementation of first scheme TMAC sometime in mid-eighties in the reactor, use of fuelling machines was questioned as availability of fuel handling system was not good and so was the case with the reactor. Due to effort put in by Fuel Handling Community (site O&M, design and R&D), performance of fuel handling system has improved significantly. In addition to increased demand of refuelling due to high capacity factor, it has been possible to cater to the increased requirement for ISI and other coolant channel related activities.

Tools developed for averting / handling emergencies in fuel handling system for PHWR will be helpful in averting the emergencies as well as to handle them in minimum possible time with minimum man-rem expenditure.

# DATA ACQUISITION SYSTEM INSTALLED

Under a MOU between BARC and National Thermal Power Corporation, a data acquisition system, designed and developed by Mass Spectrometry & Electronics Systems Section (MS&ESS), Physics Group, was recently installed at National Capital Thermal Power Station, Dadri, UP. Its primary purpose is to continuously log the plant parameters so as to enable evaluation of plant performance as well as facilitate assessment of any fatigue of the subsystems. MS&ESS built Data Acquisition System (DAS) is an integral part of a SCADA system. Acquired data can be used for control and/or post analysis, and thus this DAS is specially engineered so as to be able to acquire data reliably and continuously over all 365 days of the year. The specifications of the system are as follows :

Data Acquisition Card (DAAD232) :

- 32 channel analog input with 12-bit resolution
- IV/2.5V/5V/10V Unipolar input
- $\pm IV / \pm 2.5V / \pm 5V / \pm 10V$  Bipolar input
- Two  $\pm 10V$  analog output with 16 bit resolution
- ISA Bus interface

Signal Conditioning Module (TcmA-44) :

- 4 Current Loop (4-20mA) inputs
- 4 K-type Thermocouple inputs

PC Acquisition Software :

- Acquisition of Process Parameters
- Trend Display for 10 hrs. of Data
- Storage of the Data for further processing
- Configuration of the Software

Block Diagram :

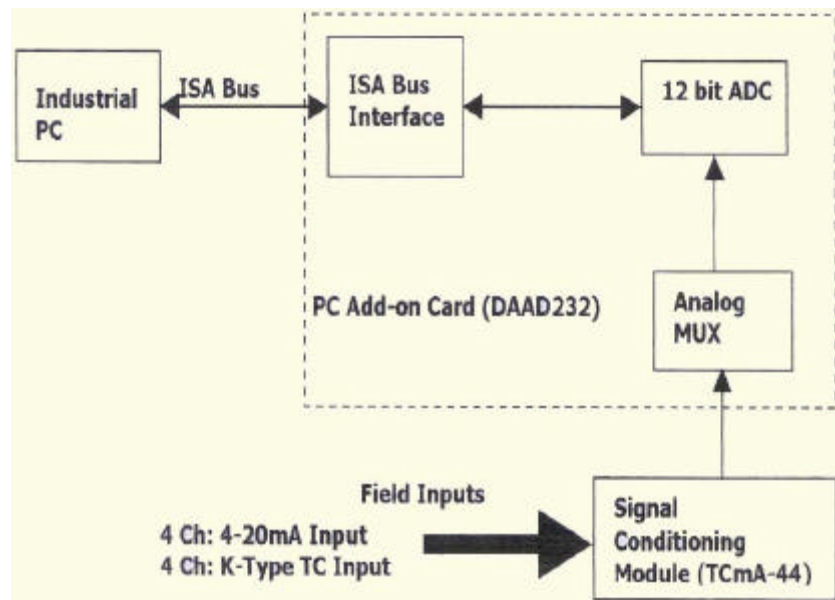

8 channel PC based Data Acquisition System



At present, NTPC is monitoring only three plant parameters, viz. hot re-heat (HRH) pressure, HRH temperature, and boiler load index (flow). Additional parameters will be added in future as and when provided by NTPC. In the graph given in the previous page is shown the typical trend of data acquired in 24 hours on April 25, 2003. This data will be further processed by the online fatigue and creep analysis software being developed by Reactor Safety Division.



## MoU SIGNED BETWEEN BARC AND NPCIL

The integrity of Zirconium alloy pressure tubes of Indian Pressurised Heavy Water Reactors is largely governed by a life limiting material degradation mechanism, called hydriding. For assessment of safe operating life of pressure tube, it is necessary to establish hydrogen pick-up rate in the tube under the operating condition by periodically estimating the total hydrogen concentration built-up into it. In order to accomplish the above objective, it is required to remove the sample without affecting the integrity of the pressure tube.



*Wet Scrapping Tool (WEST)*

A remotised and non-destructive technique, known as Sliver Sample Scraping Technique, has been developed at Reactor Engineering Division, BARC, to obtain *in-situ* sliver samples from specified location within the bore of the pressure tube for determination of its residual service life. In the process, a sliver sample of 0.1mm thickness and 90 mg average weight is obtained in such a way that the scraped region, contour created inside the bore of the pressure tube, does not lead to loss of its integrity.



*Mr S.A. Bhardwaj, Director(Engg), NPCIL, handing over a cheque to Mr R.K. Sinha, Associate Director, RD&DG, BARC*

Based on the Sliver Sample Scraping Technique, Wet Scrapping Tool (WEST) has been jointly developed by Reactor Engineering Division and Refuelling Technology Division. WEST tool utilises existing Fuelling Machines for obtaining sliver samples remotely, thus saving the time and man-rem expenditure. WEST extensions and associated procedures have been developed by Refuelling Technology Division to operate the tool inside the pressure tube with fuelling machine rams. Centre for Design and Manufacture, BARC, has been associated with manufacturing of WEST tools and extensions.



*On an occasion after signing MoU, seen third from left are Mr R.J. Patel, Head, FHDDS, RTD, Mr A. Manjunatha, Head, CDM, Mr S.A. Bhardwaj, Director(Engg) NPCIL, Mr R.K. Sinha, Associate Director, RD&DG and Mr B.B. Rupani, Head, RCCS, RED. Mr D. Saha, Head, RED, Mr R.G. Agrawal, Head, RTD and Dr V. Venugopal, Head, FCD were also present on the occasion.*

WEST has been successfully used for obtaining sliver samples from five pressure tubes of MAPS-1 in August 2001, four pressure tubes of MAPS-1 in September 2002, 87 pressure tubes of RAPS-1 in October-November 2002 and six pressure tubes of NAPS-2 in April 2003.

A Memorandum of Understanding (MoU) between BARC and NPCIL was signed in March, 2003 by Mr G. Govindarajan, Director, A & M Group, BARC, and Mr S.A. Bhardwaj, Director (Engg), NPCIL, to manufacture WEST tools and Extensions at Centre for Design & Manufacture, BARC, for NAPS, MAPS and KAPS and to train the NPCIL personnel for maintenance and operation of the tool. Recently, on March 26, 2003, in a brief ceremony, Mr S.A. Bhardwaj,

Director (Engg), NPCIL, handed over a cheque to Mr R.K. Sinha, Associate Director, Reactor Design & Development Group (RD&DG), BARC, for the completion of the supply of first lot of WEST under this MoU. This important milestone signified the assimilation of this complex technology for large scale deployment in Indian PHWRs.

## NUCLEAR AND RADIOCHEMISTRY SYMPOSIUM (NUCAR 2003)

The 6<sup>th</sup> biennial BRNS-DAE symposium on "Nuclear and Radiochemistry (NUCAR 2003)" was held during February 10-13, 2003 at the Multipurpose Hall of BARC Training School Hostel. The inaugural function of the symposium was held on February 10, 2003. Dr S.B. Manohar, Chairman, Symposium Organising Committee, welcomed the delegates. Dr B.S. Tomar, Convener, presented the theme of the symposium highlighting the objective and giving details of the deliberations. Dr J.P. Mittal, Director, Chemistry & Isotope Group, BARC, in his address, emphasised the need to spread the subject of Nuclear and Radiochemistry to Universities. Mr B. Bhattacharjee, Director, BARC, in his presidential address, described the important role played by Radiochemists in the Nuclear Fuel Cycle. In the inaugural address, Dr Anil Kakodkar, Chairman, Atomic Energy Commission, asked the delegates to focus their efforts towards more productive and goal-oriented programmes. He also lauded the efforts of IANCAS towards spreading the subject of Radiochemistry to various Universities. Mr M.K.Saxena, Secretary of the symposium organizing committee, proposed the vote of thanks.



*Dr Anil Kakodkar, Chairman, AEC, delivering the inaugural address of the symposium*

The technical programme of the NUCAR 2003 included 14 invited talks, 38 oral presentations and 215 poster presentations. The highlight of the symposium was a special seminar on applications of accelerators, which included invited talks on Accelerator Driven sub-critical reactor Systems (ADS), Medical Cyclotrons and Ion Beam Analysis. This session was chaired by Prof. S.S. Kapoor. A total of 330 registered delegates participated in the symposium.

# 13<sup>TH</sup> BARC-NPCIL TRAINING WORKSHOP

A Training Workshop on "Planning, Preparedness and Response to Radiological Emergencies" for DAE officials was held at NAPS, Narora, during March 24-28, 2003. A total of 28 officers in the grade Shift Charge Engineer/Asst. Shift Charge Engineer, Senior Officers from Health Physics Units/ESLs from various Nuclear Power stations, Research Reactors and Reprocessing Plants participated in this workshop. The faculty consisted of senior officers from BARC, NPCIL and AERB.

Dr V. Venkat Raj, Director, HS&EG, BARC, formally inaugurated the course on March 24, 2003. Mr S.A. Bhardwaj, Director (Eng), NPCIL, Mr O.P. Goyal, Station Director, NAPS, Mr R.M. Sharma, Head, HPD, BARC, and Mr J.P. Gupta, Chief Suptdt., NAPS, were the dignitaries present on this occasion and who addressed the gathering on the relevance and Importance of this Training Workshop. Senior officers of NAPS, invited guests and members of the local press were also present. In his inaugural address, Dr V. Venkat Raj, Director, HS&EG, BARC, emphasised the importance of remaining well informed and ever alert to deal with an unlikely event of a nuclear emergency. He appreciated that emergency response exercises were regularly conducted at all centres and the procedures were updated periodically. He stressed on streamlining and standardising the procedures so that any confusion and panic could be avoided in case of an event leading to an emergency situation. He recalled that Emergency Response Exercises were carried out at NAPS even before the units became operational and that it showed the importance given to such preparedness in DAE.

In his welcome address, Mr O.P. Goyal, Station Director, NAPS, briefed the importance given to Training activities at NAPS, Narora. He also mentioned that at NAPS emergency response exercises are being conducted periodically.



*Participants of the Training Workshop along with the faculty members and dignitaries. Seated (from left) are: Dr B.S. Rao, RP&AD, BARC, Dr A. Shringi, HSE&PA, NPCIL, Mr R.M. Sharma, Head, Health Physics Division, BARC, Mr S.A. Bhardwaj, Director (Eng), NPCIL, Dr V. Venkat Raj, Director, HS&EG, BARC, Mr O.P. Goyal, SD, NAPS, Mr J.P. Gupta, CS, NAPS, Mr Ramesh Chandra, ENC (TRG), NAPS, Mr K. Narayanan Kutty, OIC, Training Group, HPD, BARC*

Mr K. Narayanan Kutty, Member-Secretary, Organising Committee, briefly explained the structure of the course and gave a broad outline of the 5 day training programme. He highlighted the importance given to the practical aspects, i.e. desk-top exercises, discussions and interaction between the participants.

Mr R.M. Sharma, Head, HPD, BARC, also addressed the gathering. He recalled the pioneering jobs carried out at RAPS, Kota, and MAPS, Kalpakkam, for standardising the procedures and preparation of Emergency Response Manuals as per the guidelines issued by AERB. He also recalled the commendable work done at all NPPs in preparing detailed documents and emergency response plans and procedures.

The local newspapers of March 25, 2003 had prominently reported about this Training programme and had appreciated the importance given for ensuring safety in the Nuclear Power Programme.

The 5-day workshop consisted of lectures, Invited talks, desk-top exercises and technical visits.

The following Invited talks were delivered :

1. New concepts of Intervention Criteria and Emergency Planning Zoning Schemes by Mr R.M. Sharma, Head, HPD, BARC.
2. Engineered Safety Features with special reference to AHWR by Mr S.A. Bhardwaj, Director (Eng), NPCIL.
3. Design Basis Events and Beyond Design Basis Events in Nuclear Reactors and Some Associated Safety Related Phenomena by Dr V. Venkat Raj, Director, HS&EG, BARC.
4. An Overview of Emergency Response System at DAE by Mr K. Muralidhar, Secretary, AEC/Member-Secretary, CMG, DAE, Anushakti Bhavan.
5. Emergency Planning, Response System & Experience at NAPS, Narora, by Mr A.R. Bansal, Operations Suptdt., NAPS.
6. Exposure Control Methods for Indian Reactors by Mr R. Venkat Raman, OPSD, AERB.

The following Desk-top Exercises were conducted :

1. Meteorological Aspects and Dose Estimation.
2. Emergency Procedure for Transport of Radioactive Materials.
3. Handling of Given Scenarios on Nuclear and Radiological Emergencies.

There was also a session exclusively devoted to presentations by the participants on the experience gained in conducting the Emergency Response Exercises at different sites. This was an interactive one, with discussions and free exchange of ideas and experiences among the participants.

The last session of the course was devoted exclusively for a desk-top exercise of handling emergency situations. The participants were

divided in two groups and were given two scenarios – one on Nuclear Emergency and the second on Radiological Emergency. They formed different working groups with defined responsibilities and recorded the chronological events and actions taken by the designated agencies. This session concluded with detailed presentations and discussions by the two teams.

In the feed-back session held on March 28, 2003, the participants freely expressed their views on the course and made suggestions to further strengthen the course.

The training course concluded with the valedictory function held on March 28, 2003. Mr J.P. Gupta, Chief Suptdt., NAPS, graced the occasion as Chief Guest. In his valedictory address, Mr Gupta congratulated the participants for their keen interest in the subject and for taking active participation in the proceedings of the course. He appreciated that such courses help in exchanging the experience gained and will improve the Emergency Response System at different units.

The chief guest presented certificates to all the participants who had successfully completed the course.

## भा.प. अ. केंद्र के वैज्ञानिकों को सम्मान / BARC SCIENTISTS HONOURED



- डॉ एम. सी. अबानी, पूर्व अध्यक्ष, विकिरण संरक्षा प्रणाली प्रभाग तथा इस समय भाभा परमाणु अनुसंधान केंद्र में सलाहकार, को इन्डियन एसोसियेशन फॉर रेडियेशन प्रोटेक्शन (IARP)

द्वारा वर्ष 2002 के लिये डॉ ए. के. गांगुली ओरेशन पुरस्कार से सम्मानित किया गया है। यह पुरस्कार दो वर्षों की अवधि में एक बार ऐसे व्यक्ति को दिया जाता है जिनका विकिरण संरक्षण में महत्वपूर्ण योगदान रहा हो।

पूर्व अध्यक्ष, विकिरण संरक्षण प्रणाली प्रभाग (RSSD), तथा संस्थापक सदस्य-सचिव, सुरक्षा समिति (BSC), की हैसियत से डॉ अबानी भाभा परमाणु अनुसंधान केंद्र, ट्राम्बे तथा इसकी अन्य शाखाओं में सम्पूर्ण विकिरण संरक्षण कार्यक्रम का निरीक्षण कर रहे थे। गामारे स्पेक्ट्रोमीटरी तथा इन्टरनल डोसिमिटर के क्षेत्र में इनकी विशेषज्ञता है। डॉ अबानी के नेत्रत्व में कई सॉफ्टवेयर पैकेजों का विकास हुआ जिनमें डोस मेनेजमेन्ट सॉफ्टवेयर भी शामिल है तथा डोस मेनेजमेन्ट के उद्देश्य से नाभिकीय शक्ति संयंत्र की सुविधाओं के लिये प्रयोग में लाया जाता है। डॉ अबानी ने आपत्कालीन सन्नद्धता के क्षेत्र में भी महत्वपूर्ण योगदान दिया है।

यह पुरस्कार डॉ अबानी को एक प्रशस्ति-पत्र तथा चाँदी के स्मृति-पट के रूप में मार्च 5, 2003 को कल्पाकम में आयोजित IARP के 16वें सम्मेलन में भाभा परमाणु अनुसंधान केंद्र के निदेशक श्री. बी. भट्टाचारजी के द्वारा प्रदान किया गया। अपने भाषण में डॉ अबानी ने "न्यु ह्यूमन रेस्पिरैट्री ट्रेक्ट मॉडल" New Human Respiratory Tract Model पर भी प्रकाश डाला।

Dr M.C. Abani, former Head, Radiation Safety Systems Division, BARC, and Consultant to BARC at present, has been awarded the Dr A.K. Ganguly Oration Award for the year 2002 by the Indian Association for Radiation Protection (IARP). This award is given, once in 2 years, to a person who has contributed significantly in the field of radiation protection.

As former Head, RSSD, and founder Member-Secretary of BARC Safety Council (BSC), Dr Abani was overseeing the complete radiation protection programme at BARC and its units outside Trombay. His main fields of specialisation are Gamma Ray Spectrometry and Internal Dosimetry. Under his leadership, many software packages have been developed including the Dose Management Software, which is used at all the nuclear power plants and other nuclear facilities in the country, for the purpose of dose management. He has also contributed significantly in the field of emergency preparedness.

The award carries a citation and a silver plaque. It was presented to Dr Abani on March 5, 2003 by Mr B. Bhattacharjee, Director, BARC, at the 26<sup>th</sup> IARP Conference held at Kalpakkam. As a part of the oration, Dr Abani gave a talk on the "New Human Respiratory Tract Model".



- श्री तपस दास, रेडियो भेषणप्रभाग, को मार्च 15, 2003 को इन्डियन इन्सटिट्यूट ऑफ टेक्नालोजी, पवई, मुंबई में आयोजित एक समारोह में "बेस्ट प्रजनटेशन पुरस्कार"

से

सम्मानित किया गया। यह पुरस्कार फरवरी, 2003 के दौरान मुम्बई विश्वविद्यालय में 15वें रिसर्च स्कूलर्स मीट (RSM) में आर.डी. नेशनल कालेज तथा डब्लू.ए.साइन्स कालेज, बान्द्रा में आयोजित एक बैठक में "लेबल्ड स्टीरियोडिस एज ड्राइगनोस्टिक एन्ड थिरापियोटिक एजन्ट्स" labeled steroids as diagnostic and therapeutic agents नामक प्रस्तुति के लिये दिया गया। इन्डियन रसायनिकी सोसाइटी के द्वारा यह सम्मेलन प्रतिवर्ष विद्वानों को रसायनिकी में शोध-पत्र प्रस्तुत करने पर प्रोत्साहन देने के उद्देश्य से आयोजित किया जाता है।

श्री तपस दास की प्रस्तुति को 32 भागीदारों में से सर्वोत्तम माना गया था, जिनमें इन्डियन इन्सटिट्यूट ऑफ टेक्नालोजी, भाभा परमाणु अनुसंधान केंद्र, यूनिवर्सिटी इन्सटिट्यूट ऑफ वैमिकल टेक्नालोजी, इन्सटिट्यूट ऑफ साइन्स तथा मुम्बई विश्वविद्यालय से सहबन्धित कई विद्वान शामिल थे। श्री दास अपना शोध-निबन्ध डॉ एम.

आर.ए. पिल्लई, अध्यक्ष, रेडियो भेषण प्रभाग, के निर्देशन में लिख रहे हैं ।

Mr Tapas Das of Radiopharmaceuticals Division, BARC, was awarded the "Best Presentation Award" by the Royal Society of Chemistry, West India Section, on March 15, 2003 at a function held in Indian Institute of Technology, Powai, Mumbai. The award was for his presentation entitled "Labeled steroids as diagnostic and therapeutic agents" in the 15<sup>th</sup> Research Scholars' Meet (RSM) of University of Mumbai held at R.D. National College and W.A. Science College, Bandra, during February 2003. The RSM is organised by the Indian Chemical Society (Mumbai Branch) annually to give an opportunity to present the Ph.D. work of research scholars in Chemistry. Mr Tapas Das's presentation was adjudged the best among the 32 participants which included scholars from Indian Institute of Technology, BARC, University Institute of Chemical Technology, Institute of Science and a few colleges affiliated to the University of Mumbai. Mr Das is doing his Ph.D. dissertation under the guidance of Dr M.R.A. Pillai, Head, Radiopharmaceuticals Division, BARC.

*Edited and published by Dr Vijai Kumar, Head, Library & Information Services Division, Bhabha Atomic Research Centre, Trombay, Mumbai 400 085.*

*Editorial Management : T.C. Balan; Computer graphics & layout : P.A.S. Warriar*

*BARC Newsletter is also available at URL:<http://www.barc.ernet.in> (for private circulation only)*