

दूरभाष (Phone) : +91-22-2559 4966
पत्र : बार्क, ट्रॉम्बे मुंबई - 400085
Letters : BARC, Trombay, Mumbai-400085
फॅक्स (Fax) : +91-22-2550 5151



भारत सरकार

Government of India

भाभा परमाणु अनुसंधान केन्द्र

BHABHA ATOMIC RESEARCH CENTRE

Atomic Fuels Division

ट्रॉम्बे, मुंबई - 400085
Trombay, Mumbai - 400085

TENDER ENQUIRY

Ref.: AFD/SMS/ENQ/2022/41685

Date: 27/05/2022

SUBJECT: Machining of Graphite rods as per specifications.

Sealed quotation is invited for and on behalf of The President of India for machining of Graphite rods. The scope of work, technical specifications, terms and conditions are attached in Annexure-I.

1. This tender will be processed in **Two-Part Bid System**.
2. The tender submitted should have two separately sealed envelopes viz.:
 - 2.1 First envelope shall contain **Technical Bid (Part-A)**. "Technical Bid (Part-A)" must be written on the envelope.
 - 2.2 Second envelope shall contain **Commercial Bid (Part-B)**. "Commercial Bid (Part-B)" must be written on the envelope.
3. The sealed Technical Bid (Part-A) shall contain Technical details of the offer and compliance with respect to technical requirement against our tender enquiry, clearly mentioning deviations, if any.
4. The sealed Commercial Bid (Part-B) shall contain detailed quotation including basic cost, applicable taxes and commercial terms and conditions.
5. **Sealed envelopes of Technical Bid (Part-A) and Commercial Bid (Part-B) shall be kept in a Single Sealed Cover / Envelope, which shall be treated as your offer against our enquiry.**
6. Offers received as (i) technical and commercial parts in one bid, or (ii) technical and commercial bids in single envelope, or (iii) unsealed bids will be treated as **invalid** and no further communication will be made to the vendor.

7. Your offer in sealed envelope bearing “Tender Enquiry No. & Due Date” should be sent to the following address, so as to reach on or before 14/06/2022 by Registered/Speed post only:

Shri Manish Modi
Scientific Assistant / D,
Atomic Fuels Division,
Bhabha Atomic Research Centre,
Trombay,
Mumbai - 400085

8. Offer received through courier or person or after due date will be treated as invalid.

Enclosure: Annexure-I

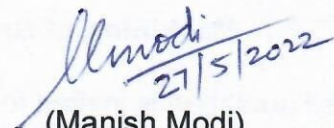
(Manish Modi)
SA/D, SMS, AFD

(M.T. Saify)
Head, SMS, AFD
For & on Behalf of President of India

Annexure-1 of Tender Enquiry

A. Brief description of the job:

Machining of Graphite rods as per specifications.

B. Scope and quantity:

1. Collection of graphite blocks (FIM) from AFD, BARC.
2. Free Issue Material (FIM) issued by the purchaser to supplier shall be covered by an insurance policy to be arranged by the supplier at his own cost. The cost of free issue material supplied to the fabricator will be Rs.5,00,000=00 (Rupees five lakh only).
3. Cutting the blocks (FIM) to suitable sizes. Available block size is given in sketch#2.
4. Final machining of rods to dimensions per the attached sketch # 1.
5. The scrap generated during the course of fabrication of 1400 Graphite rods will not be accepted back by Atomic Fuels Division and is to be accordingly handled by the vendor.
6. Transportation and safe delivery of machined rods to BARC.

Quantity: 1,400 nos.

C. Inspection & testing

All the machined Graphite rods shall be offered for inspection & trials as per order specifications to purchaser's authorised representatives at supplier's works before dispatch.

D. TERMS AND CONDITIONS:

1. **Vendor is required to quote the rate after deducting the value of scrap generated in process, as scrap will not to be accepted. The price of graphite scrap rate lump sum shall be mentioned separately.**
2. Validity: The quotation shall be valid for minimum 90 days. Supplier shall clearly mention the validity of offer in their quotation. In absence of this information and offer having validity less than 90 days will be rejected.
3. Quotations are to be printed on letter head, mentioning GST registration number and PAN of the firm. Quotations without this information are liable to be rejected.
4. The quotation should clearly mention the name of signatory and should bear company seal.
5. Please mention basic amount and GST separately in the quotation.
6. Quotations shall be sent only by Registered Post / Speed Post. Courier or hand delivery of quotations is NOT acceptable. Quotations that are received by email, fax or any other computer generated form, handwritten quotations, unsigned quotations etc. will be considered as invalid and rejected.
7. **Offer evaluation procedure:** Only Valid Technical bids will be opened first and evaluated. Commercial bids from only technically qualified vendors will be opened and the lowest quoted offer shall be recommended for placing the work order.
8. Incomplete or vague quotations will be rejected and no further communication will be made from our side in this regard.
9. Vendor/Contractor should have pre-cleared security vetting of his company/firm as per BARC security rules.
10. The contractor and/or his personnel shall have to carry a valid **photo identity card** (Aadhaar Card, Passport, Driving Licence) while visiting the premises.

11. Any type of electronic items such as mobile phone, camera, storage media like pen drives, hard disk, etc. are banned and not allowed inside office premises.
12. The contractor and/or his personnel visiting AFD for the above job should have valid police verification to work in BARC, Trombay, Mumbai.
13. The contractor and/or his personnel are not allowed to move inside BARC without an escort from the department.
14. The machining and supply shall be completed within a period of **6 months** after the placement of order.
15. The delivery period mentioned in the work order shall be strictly adhered to. Any delay which is attributable to the supplier is liable for penalty @ ½ % per week (maximum 10% to be imposed on the supplier).
16. The machined rods are to be delivered at Atomic Fuels Division, BARC, Trombay, Mumbai – 400085.
17. The payment will be made only after acceptance of fabricated and supplied items and on **submission of following documents:**
 - a. Delivery challan in duplicate.
 - b. Bill / invoice in triplicate. The bill shall clearly indicate taxes, if any.
 - c. GST undertaking.
 - d. ITR undertaking.
 - e. Advance stamped receipt in favour of Pay and Accounts officer, BARC.
 - f. ECS form: Bank details may please be furnished in the attached ECS form and submitted as payments will be released only through ECS.
 - g. A copy of cancelled cheque, required for ECS payment.
18. Advance payment / part payment / payment against delivery cannot be made.
19. Bills / invoices will be cleared only on submission of an undertaking that the GST has been promptly deposited with the authorities.
20. For amount of Rs. 30,000=00 and above, **Income Tax @ 2%** of basic cost will be deducted from your bill.
21. For amount of Rs. 2,50,000=00 and above, **GST TDS @ 2%** of basic cost will be deducted from your bill.
22. No escalation in the cost of contract will be permitted.
23. No insurance charges will be borne by the department.
24. The contractor will not be eligible to claim any interest on account of delay in receiving any payment.
25. No additional expenses towards freight, shifting charges, expenses of foreign engineers, extra visit charges, engineer expenses, transportation, refurbishment charges, overhauling charges, repair charges to bring the equipment in working condition, other charges etc. will be payable.
26. You will be bound by the confidentiality clauses mentioned below:
 - a. **Confidentiality:** No party shall disclose any information to any third party concerning the matters under this contract generally. In particular, any information identified as “Proprietary” in nature by the disclosing party shall be kept strictly confidential by the receiving party and shall not be disclosed to any third party without the prior written consent of the original disclosing party. This clause will apply to the sub-contractors, consultants, advisers or the employees engaged by a party with equal force.
 - b. **“Restricted information” categories under section-19 of the Atomic Energy Act, 1962 and “Official Secrets” under Section-5 of the Official Secrets Act, 1923:** Any contravention of the above-mentioned provisions by any contractor, sub-contractor, consultant, adviser or the employees of a contractor will invite penal consequences under the aforesaid legislation.

- c. **Prohibition against use of BARC's name without permission for publicity purposes:** The contractor, sub-contractor, consultant, adviser or the employees engaged by the contractor shall not use BARC's name for any publicity purpose through any public media like Press, Radio, TV or Internet without the prior written approval of BARC.

E. Declaration to be submitted along with the offer

The prospective supplier shall declare as to whether he has any relative working in BARC, or himself is an ex-employee of BARC, or has an ex-employee of DAE on his pay rolls.

Material: High density High purity Graphite

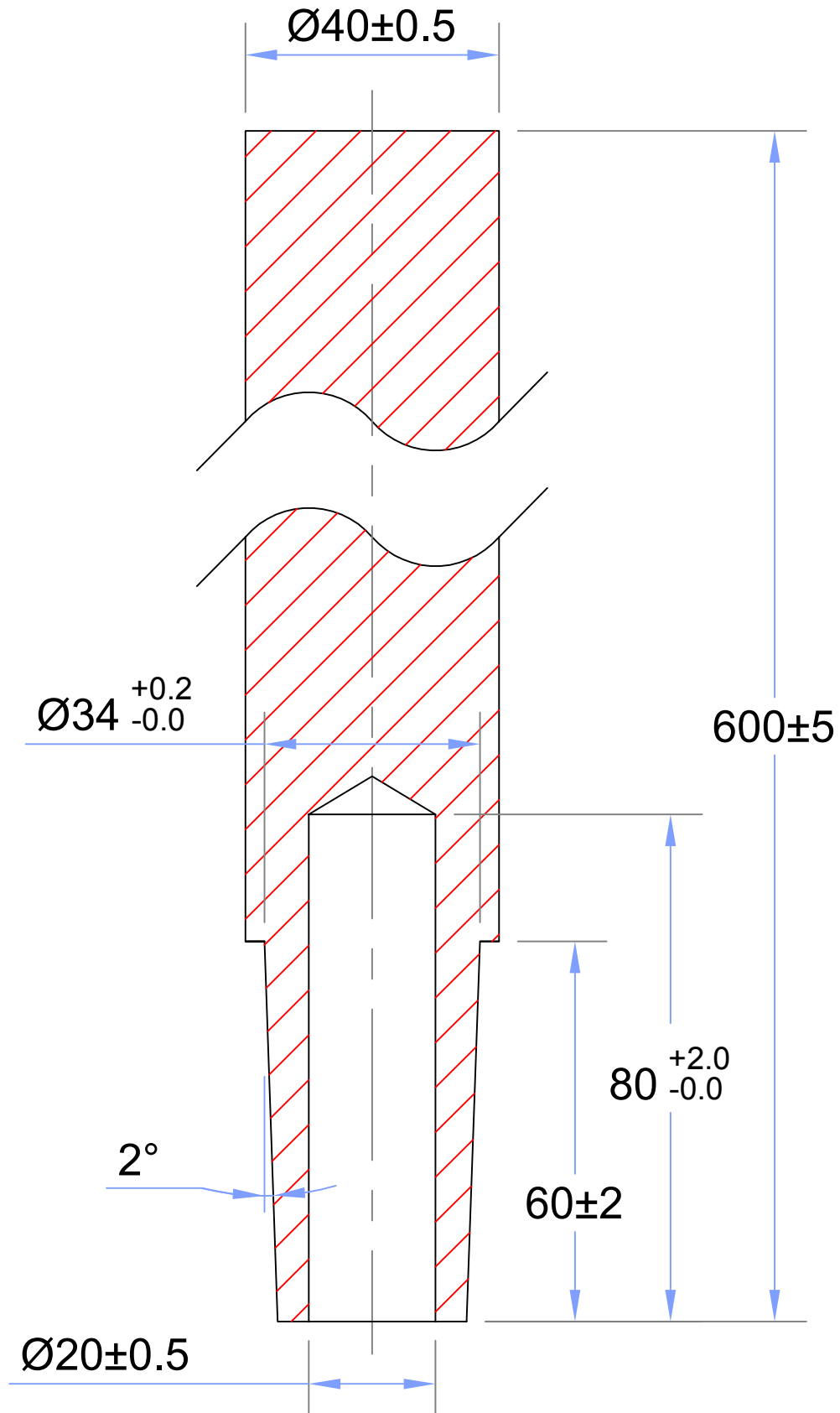

All dimensions are in mm

Sketch # 1

Graphite Rod

All dimensions are in mm

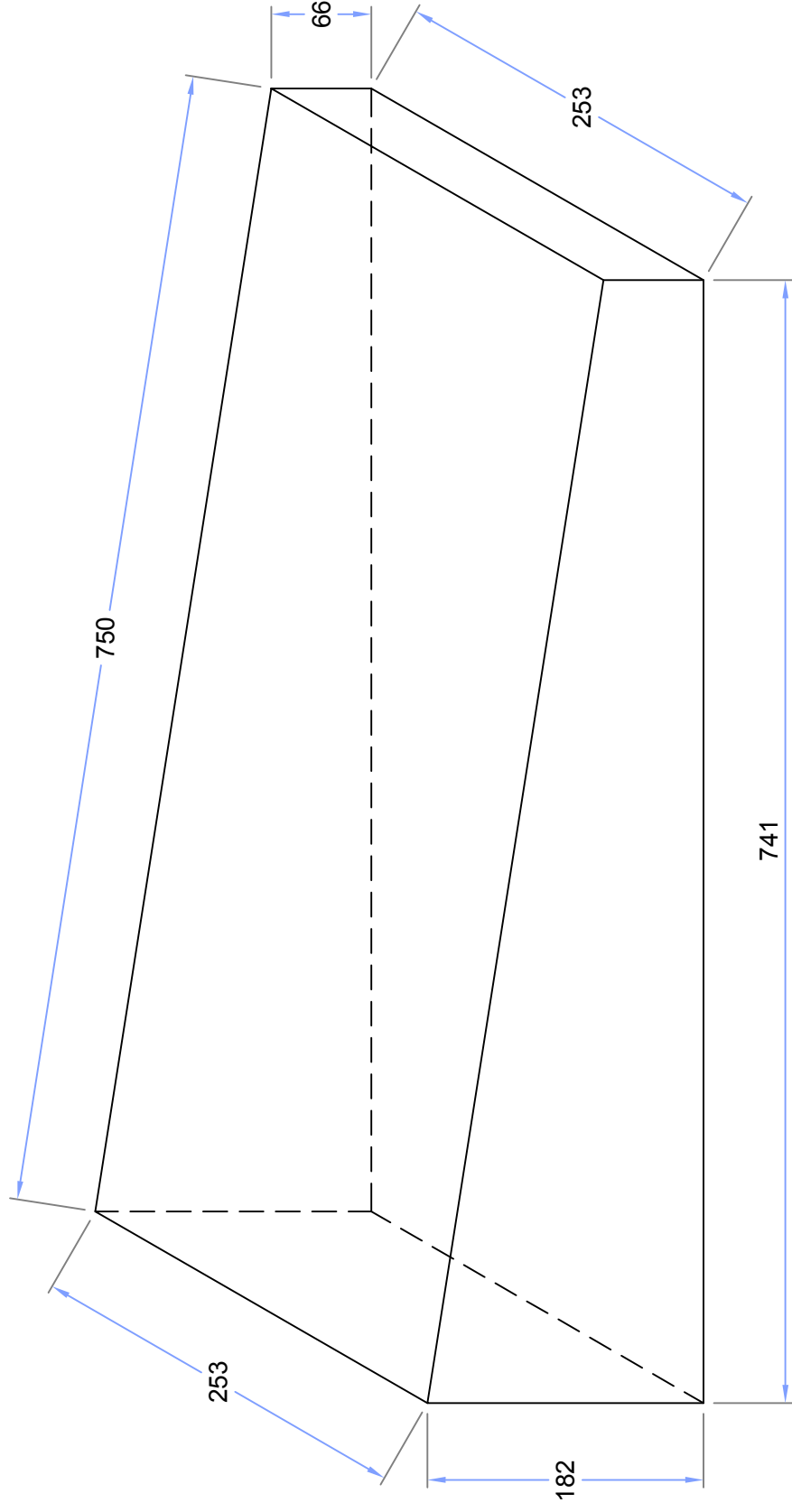

Sketch # 2

Graphite Block