



Government of India
Department of Atomic Energy
Bhabha Atomic Research Centre
Pulsed Power and Electro-Magnetics Division
Atchutapuram, Visakhapatnam - 531011



Ref: **(Ref:BARC(V)/PP&EMD/2021-22/R&D-44/WO/RS/66)**

Date: 24/02/2022

Sub: Fabrication, supply and safe delivery of high voltage vacuum electrical chamber, its parts and vacuum testing as per the drawings and specifications attached in Annexure-I.

Dear Sir/Madam

Sealed quotations are invited for and on behalf of President of India for the **Fabrication, supply and safe delivery of high voltage vacuum electrical chamber, its parts and vacuum testing as per the drawings and specifications attached in Annexure-I.**

The sealed envelope for the quotation with reference number of this enquiry shall be super scribed with **Quotation for "Fabrication, supply and safe delivery of high voltage vacuum electrical chamber, its parts and vacuum testing as per the drawings and specifications attached in Annexure-I."** and should reach **on or before 08/03/2022** to

**Dr. Archana Sharma
Head, PP&EMD
PEB-1, Near East Gate
Bhabha Atomic Research Centre
Gandivanipalem Village, Dossuru Panchayat
Atchutapuram Mandal, Visakhapatnam
Andhra Pradesh - 531011
Contact Person: Dr Rohit Shukla, Ph: 0891-2832010**

Dr. (Smt.) Archana Sharma
OS/Group Director, BTDG
BARC, Mumbai

Enclosures:

1. Annexure-I (Specifications)
2. Annexure-II (General Terms and Conditions)
3. Annexure-III (GST Undertaking)
4. Annexure-IV (Advanced Stamped Receipt)

CC: Accounts Officer, BARC(V)

Annexure - I

Ref: (Ref: **BARC(V)/PP&EMD/2021-22/R&D-44/WO/RS/66**)

Dated: 24/02/2022

Sub: Fabrication, Supply and safe delivery of high voltage vacuum electrical chamber, its parts and vacuum testing as per the drawings and specifications attached in Annexure-I.

Specifications:

Item: Fabrication, Supply and safe delivery of high voltage vacuum electrical chamber, its parts and vacuum testing as per the drawings and specifications attached in Annexure-I.

1. Quantity: As per mentioned in drawings.
2. Bidder shall quote for fabrication of these components with materials.
3. There is no free issue of materials or components.
4. Taxes shall be quoted separately.
5. The fabrication work shall be subjected to inspection by our Engineer or suitable test certificate to be decided by our Engineer. The fabrication job is required to have prior approval by our engineer before declaration of completion. Necessary inspection facilities should be provided to our engineer during fabrication.
6. Our Engineer may ask for suitable test certificate of the materials or may ask for sample piece of the materials for testing.
7. The bidder shall complete the finished components after approval by our engineer **within 6 weeks** from the date of firm work order issued to the bidder. The finished components along with left over material shall be delivered by the bidder to BARC, Visakhapatnam.
8. Head, PP&EMD reserves the rights to accept/ reject any or all quotations without assigning any reasons.
9. Delivery charges if any, must be clearly mentioned with the offer.
10. Quotation must also indicate the validity of offer. Vendors are requested to give **at-least 45 days of validity** for their quotations.
11. Drawing / sketches must be returned along with the offer.
12. Quotations are to be in printed letter-head / quotation format only. Quotation received in computer-generated forms will be considered as invalid and rejected.
13. Quotation should consists of Sales Tax registration number (Registered with local ST / CST/CGST authority), PAN number of the firm, services tax registration number etc.
14. Claim preferred by the firms are also be in printed INVOICE format consisting of the above registration numbers.
15. Vendor may contact the undersigned for any technical clarifications before quoting.

Dr. Rohit Shukla, SO – G,
Officer-in-charge, Diagnostics and Applications Group,
PP&EMD, BARC, Visakhapatnam
Contact: 0891-2832010
Email: rshukla@barc.gov.in

Dr. (Smt.) Archana Sharma
OS/Director, BTDG
BARC,Mumbai.

Detailed Technical specifications and Schematic Drawings of high voltage Vacuum electrical chamber.

(Ref: BARC(V)/PP&EMD/2021-22/R&D-44/WO/RS/66)

Dated: 24-02-2022

Drawings:

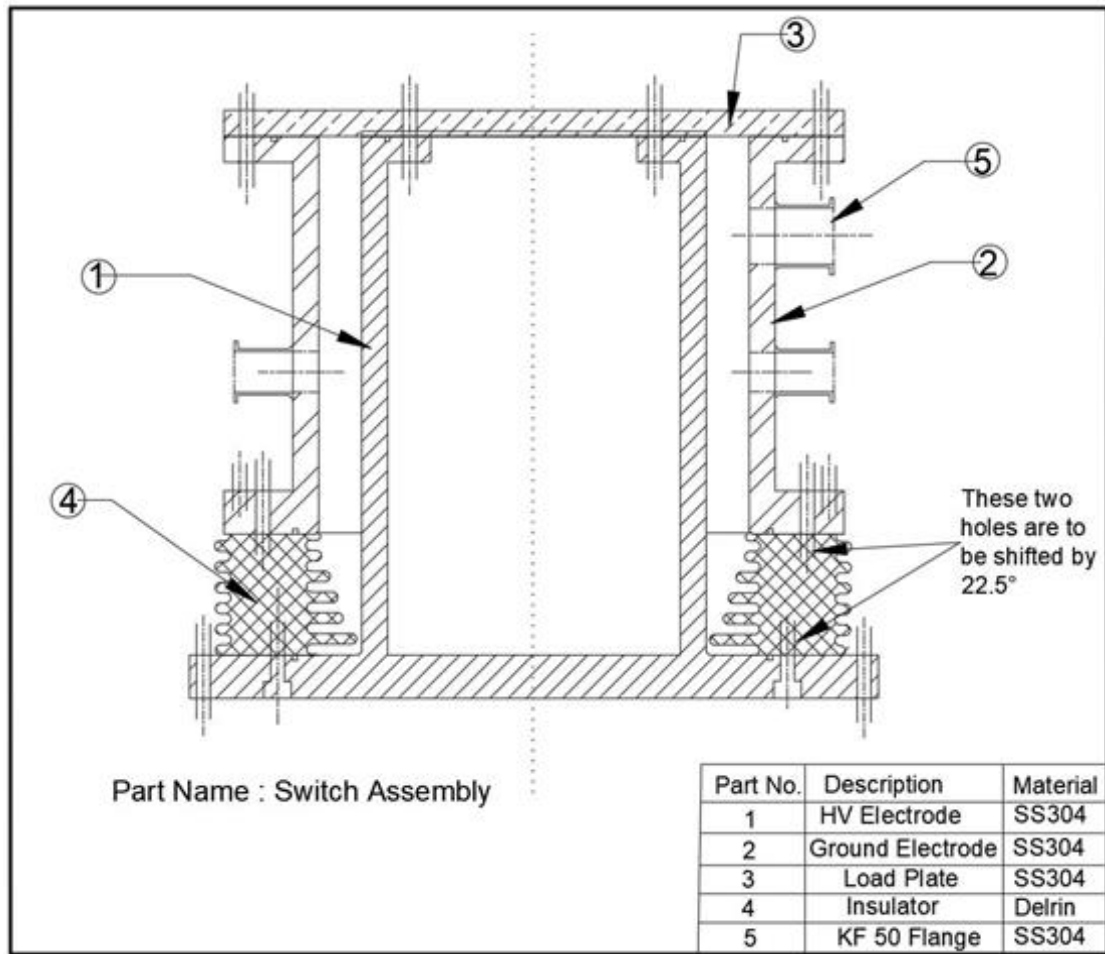
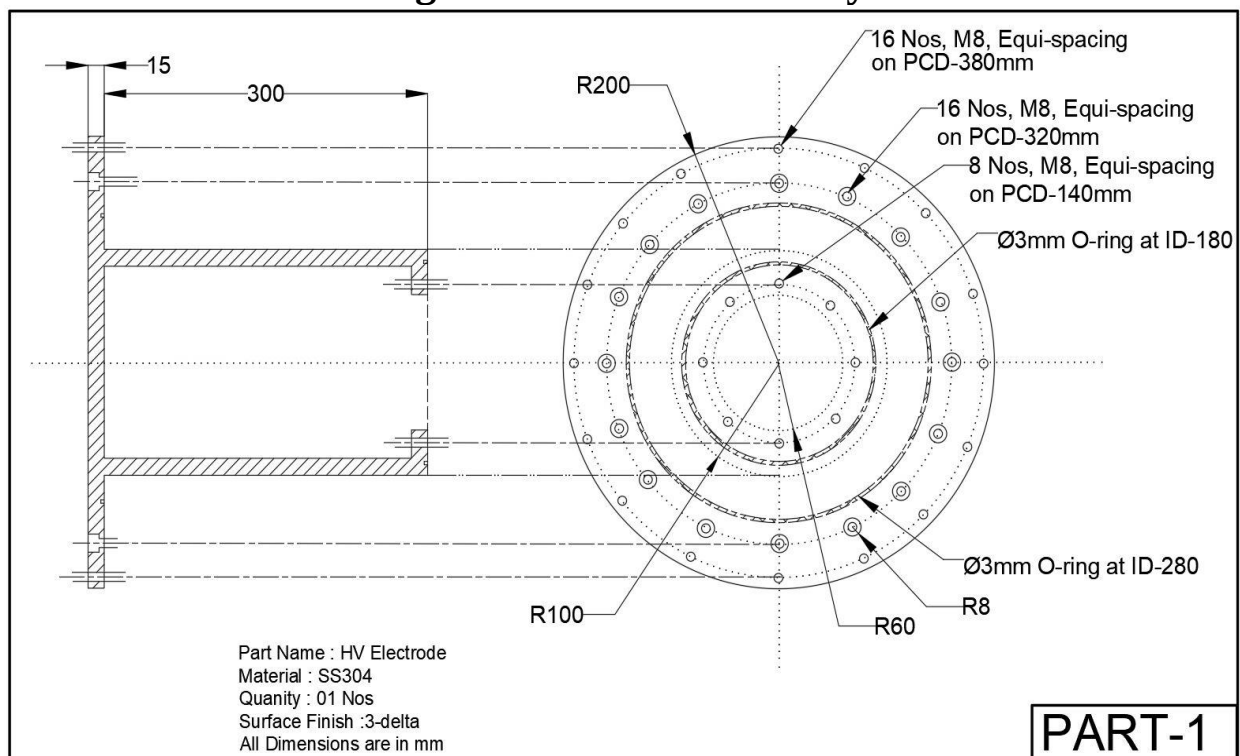

Figure-1: Switch Assembly



PART-1

Figure-2: HV Electrode

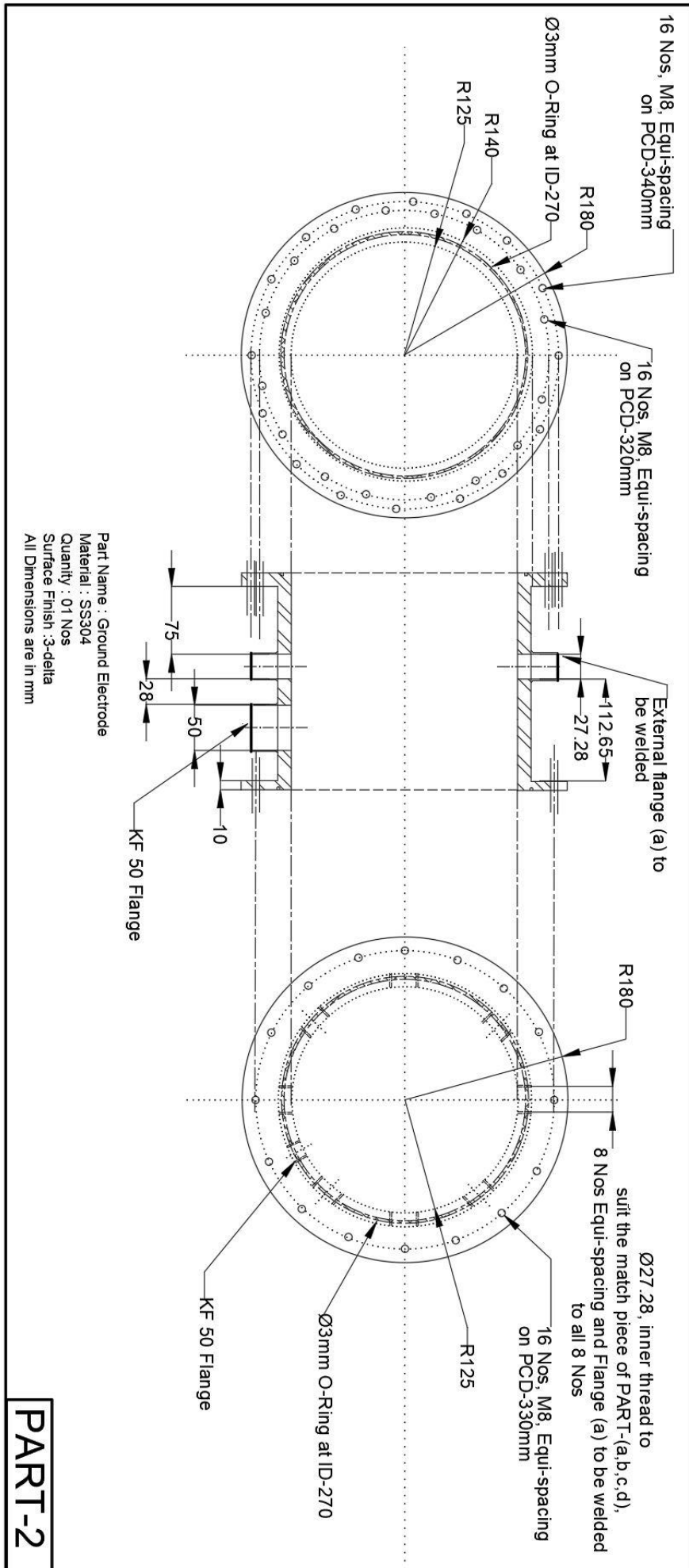

Figure-3: Ground Electrode

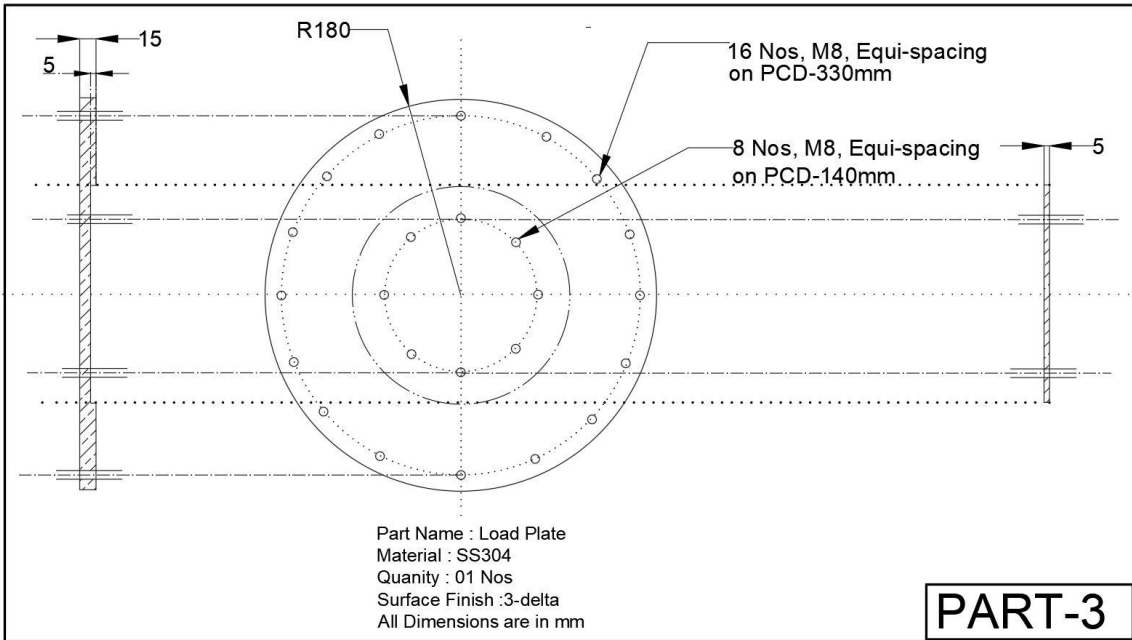

Figure-4: Load Plate

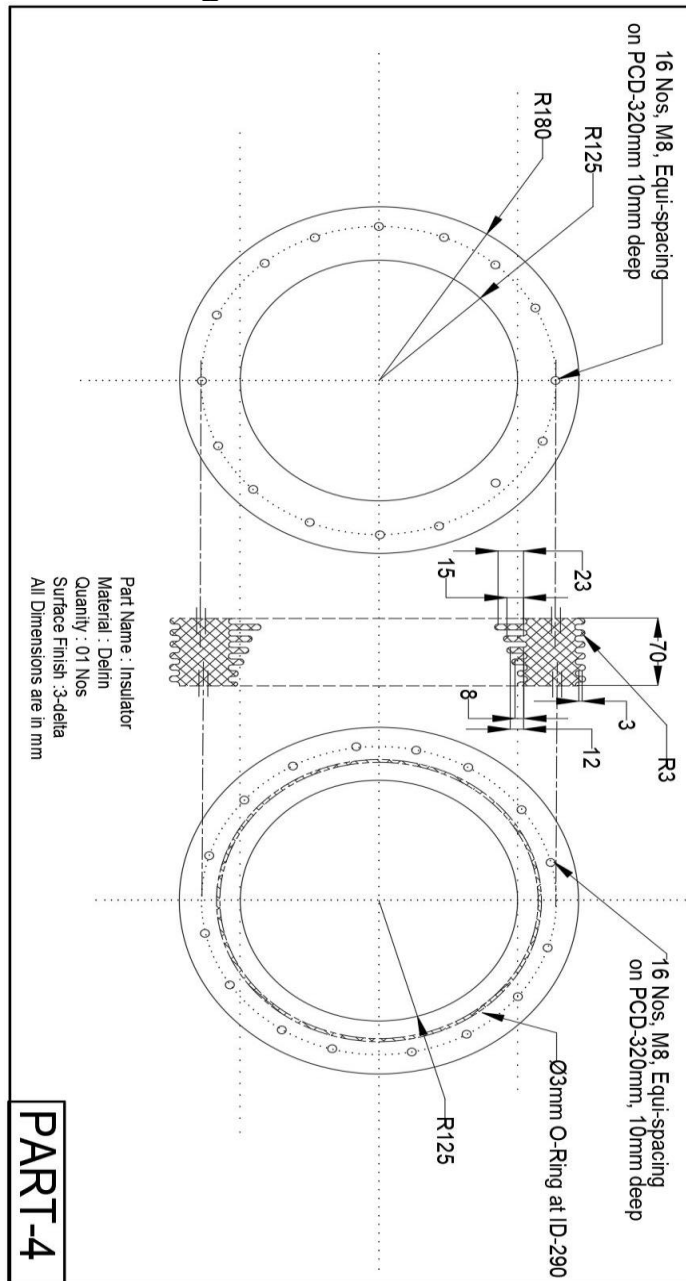

Figure-5: Insulator

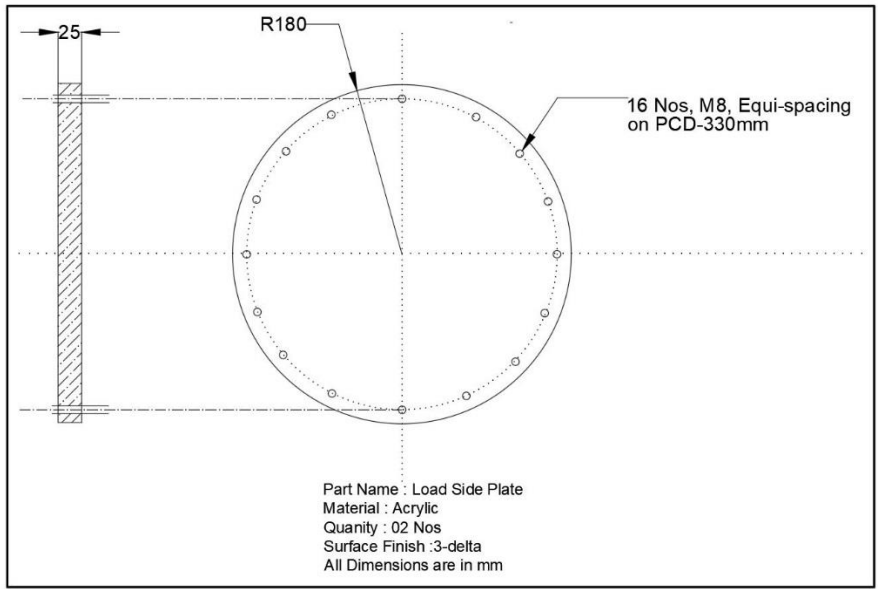

Figure-6: Load Side Plate

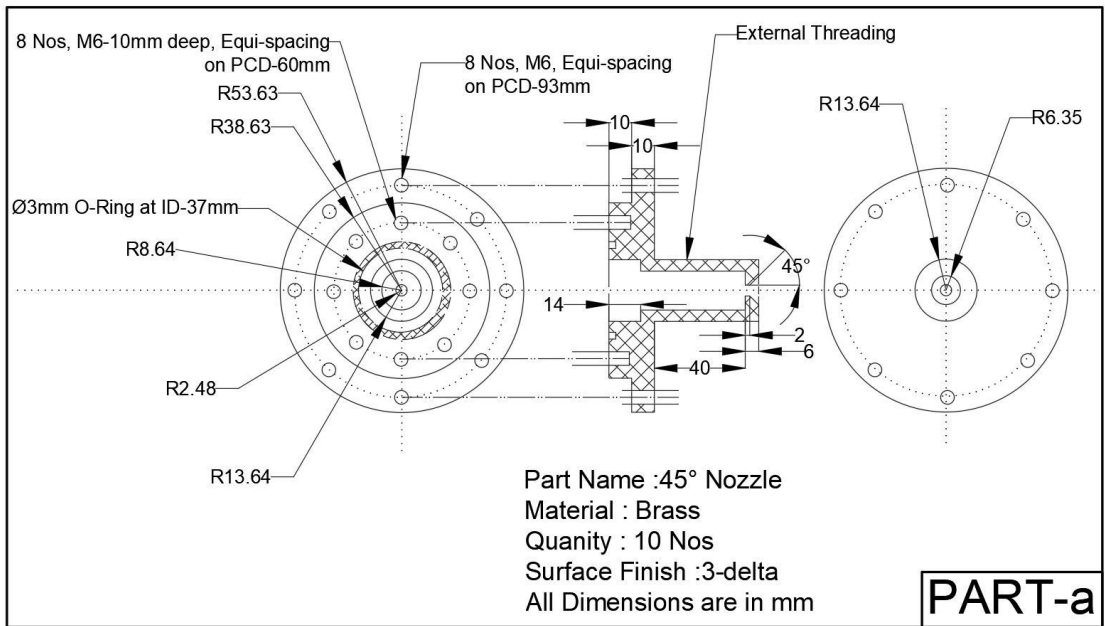

Figure-7: 45° Nozzle

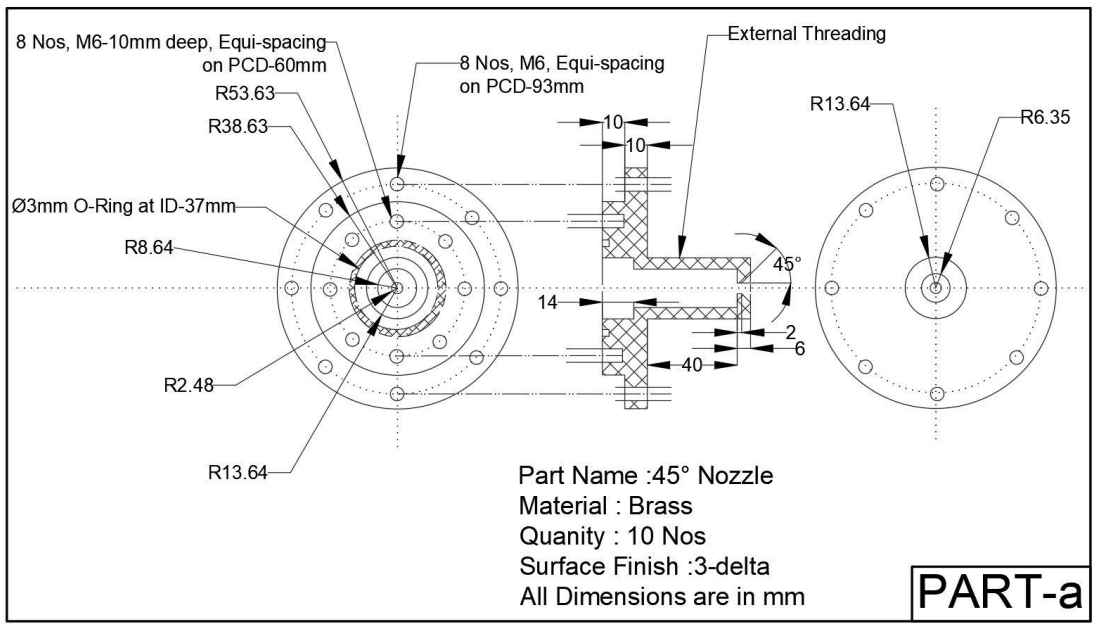

Figure-8: 30° Nozzle

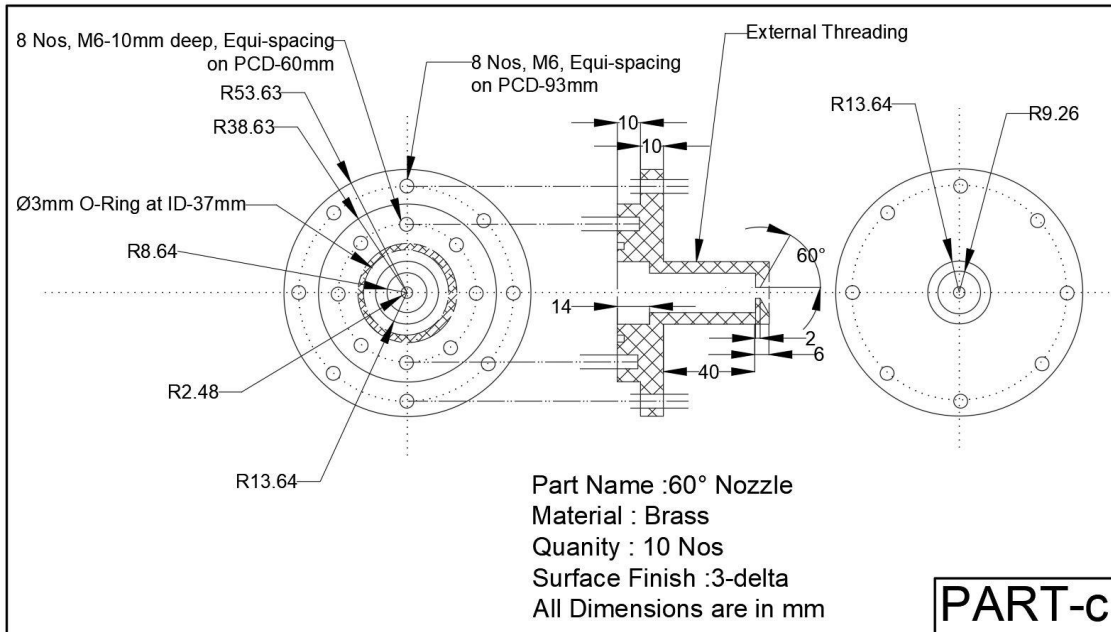

Figure-9: 60° Nozzle

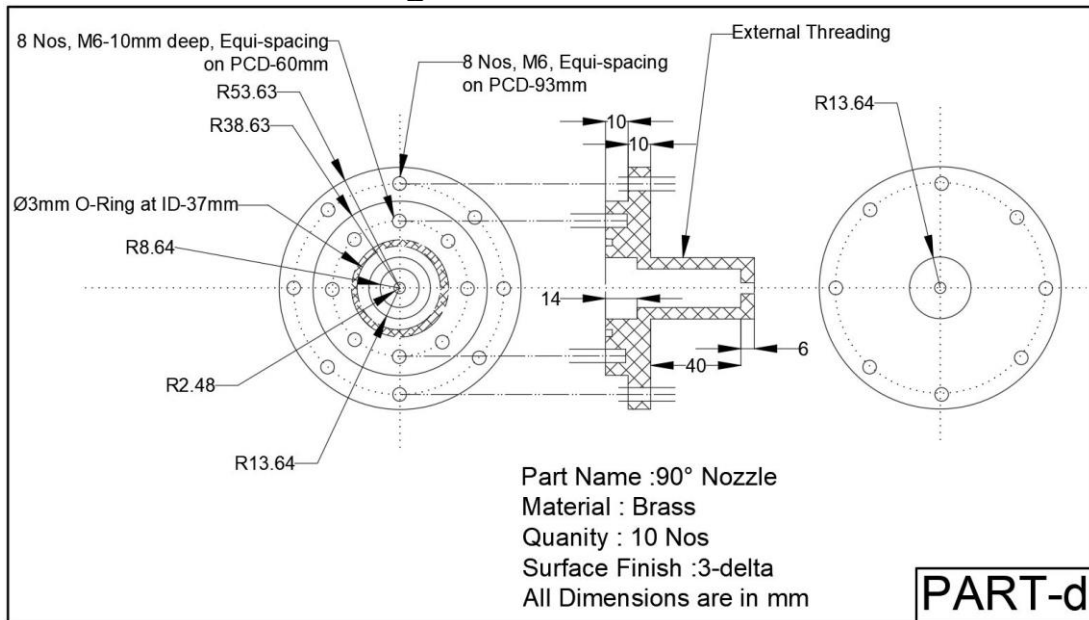

Figure-10: 90° Nozzle

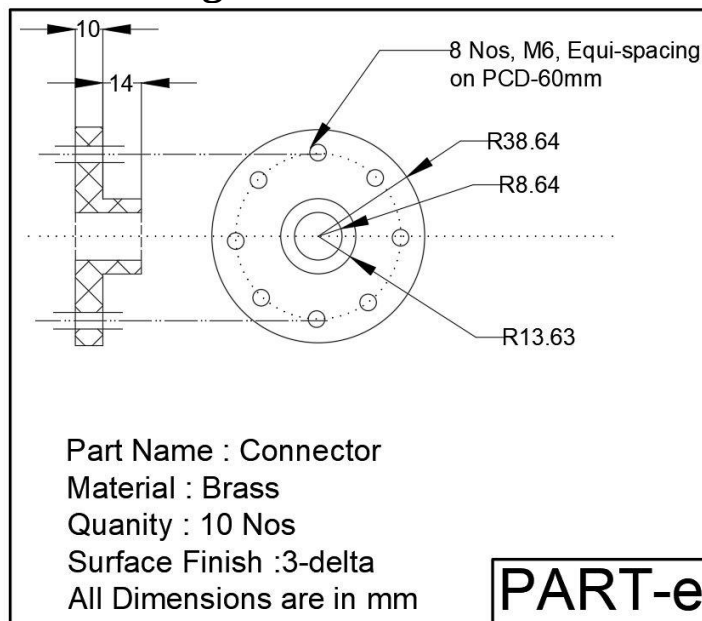

Figure-11: Connector

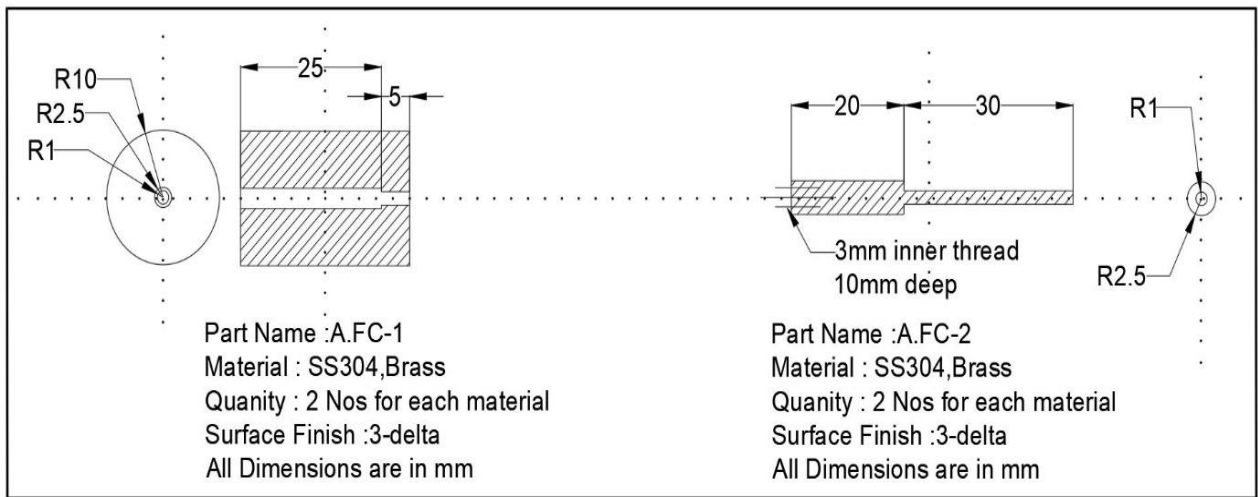

Figure-12: FC-A

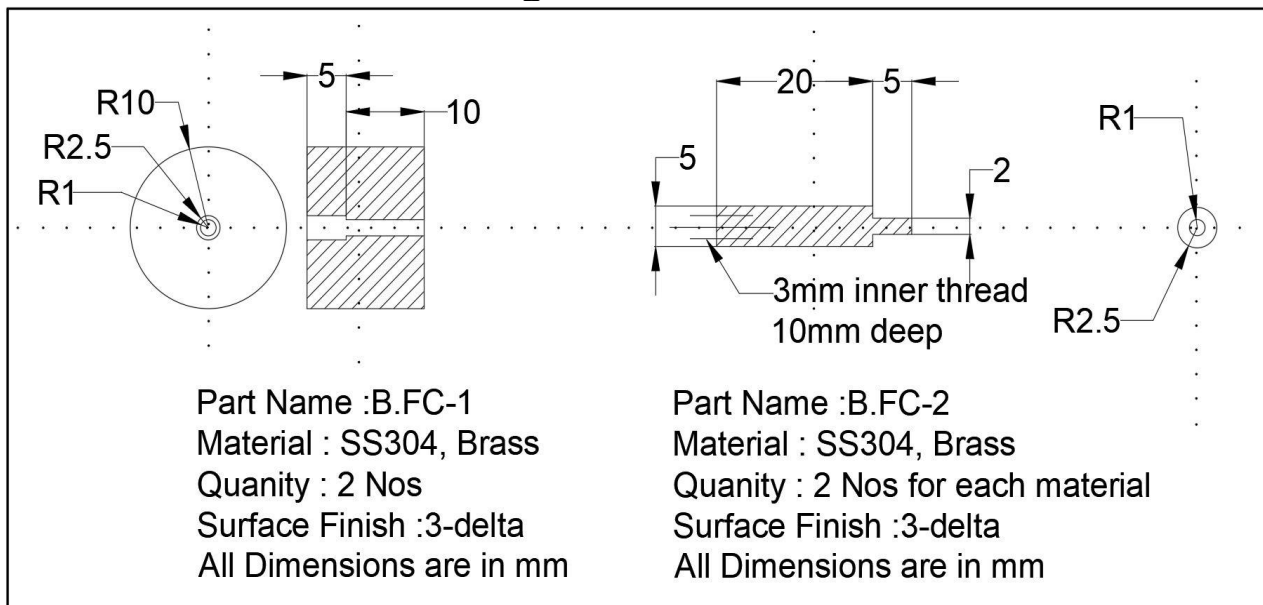

Figure-13: FC-B

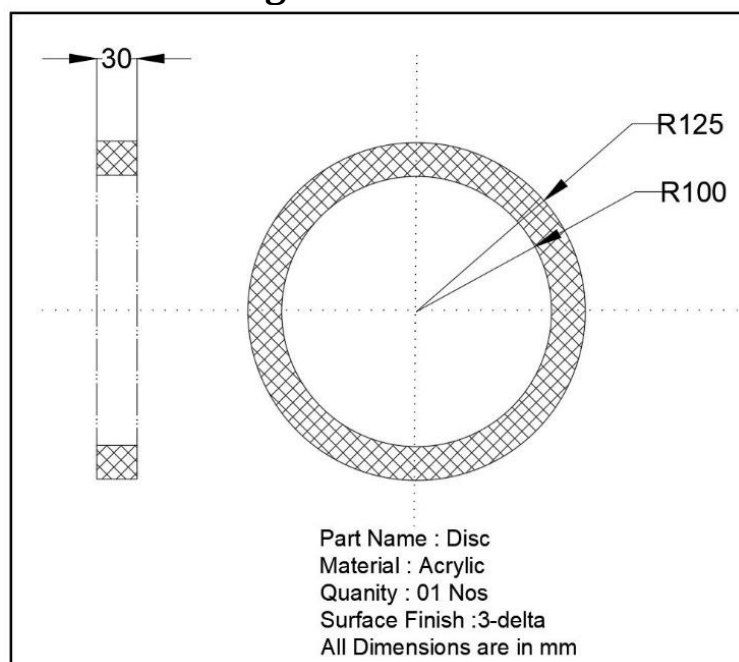

Figure-14: Disc

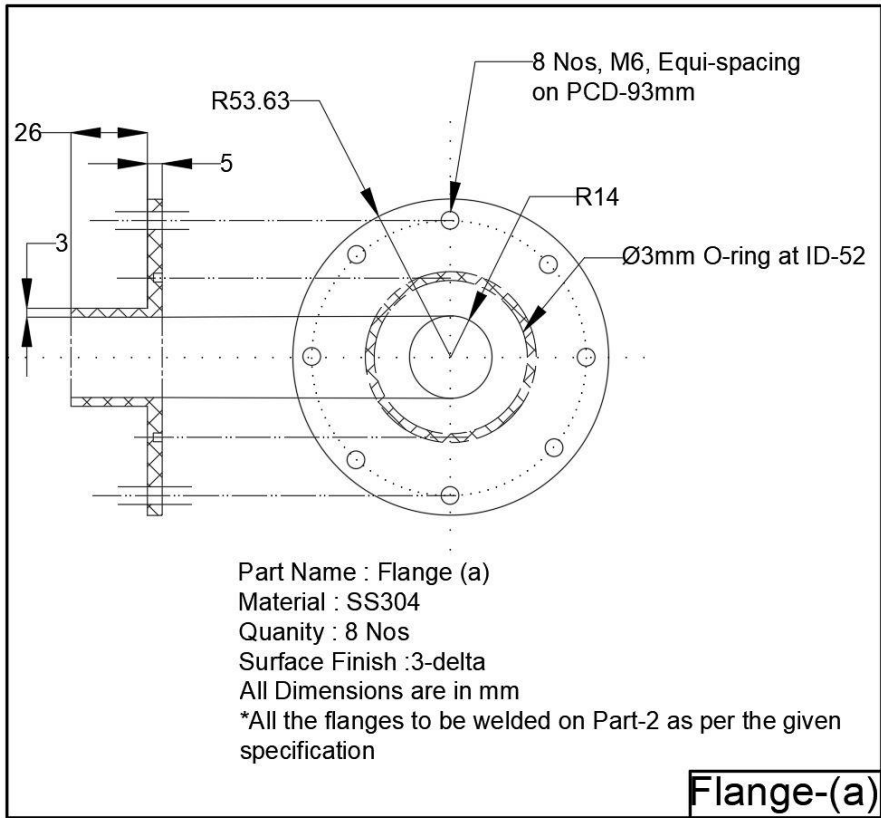

Figure-15: Flange (a)

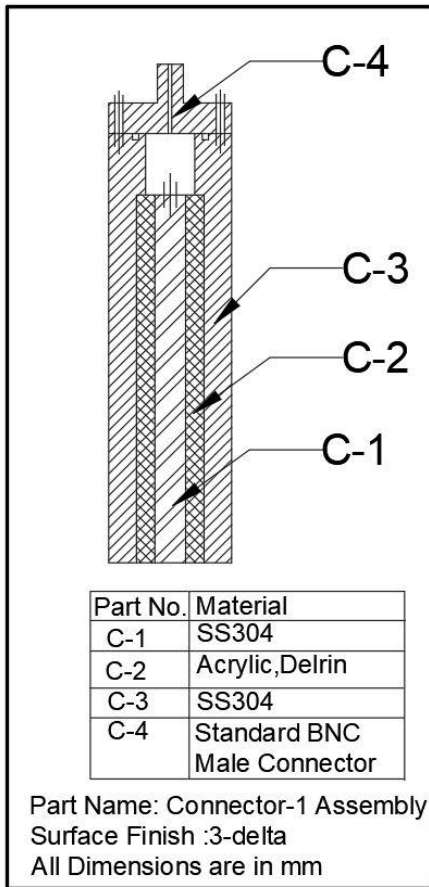

Figure-16: Connector-1 Assembly

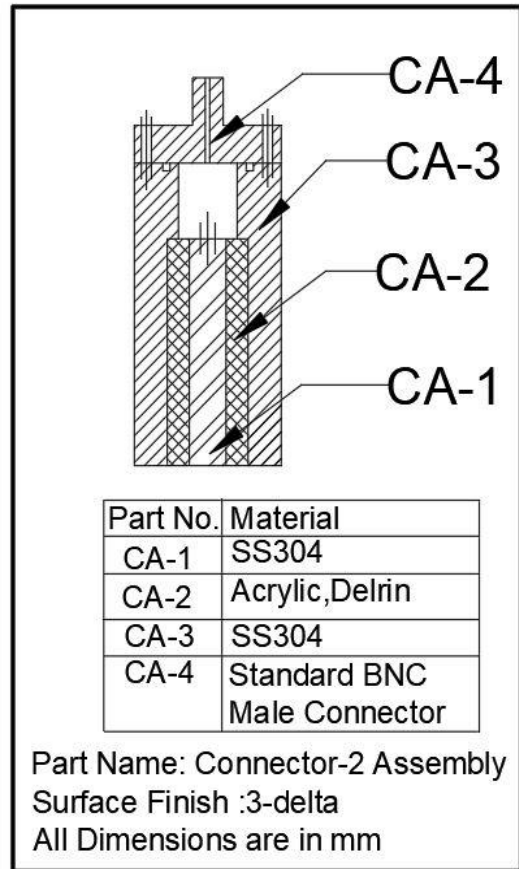

Figure-17: Connector-2 Assembly

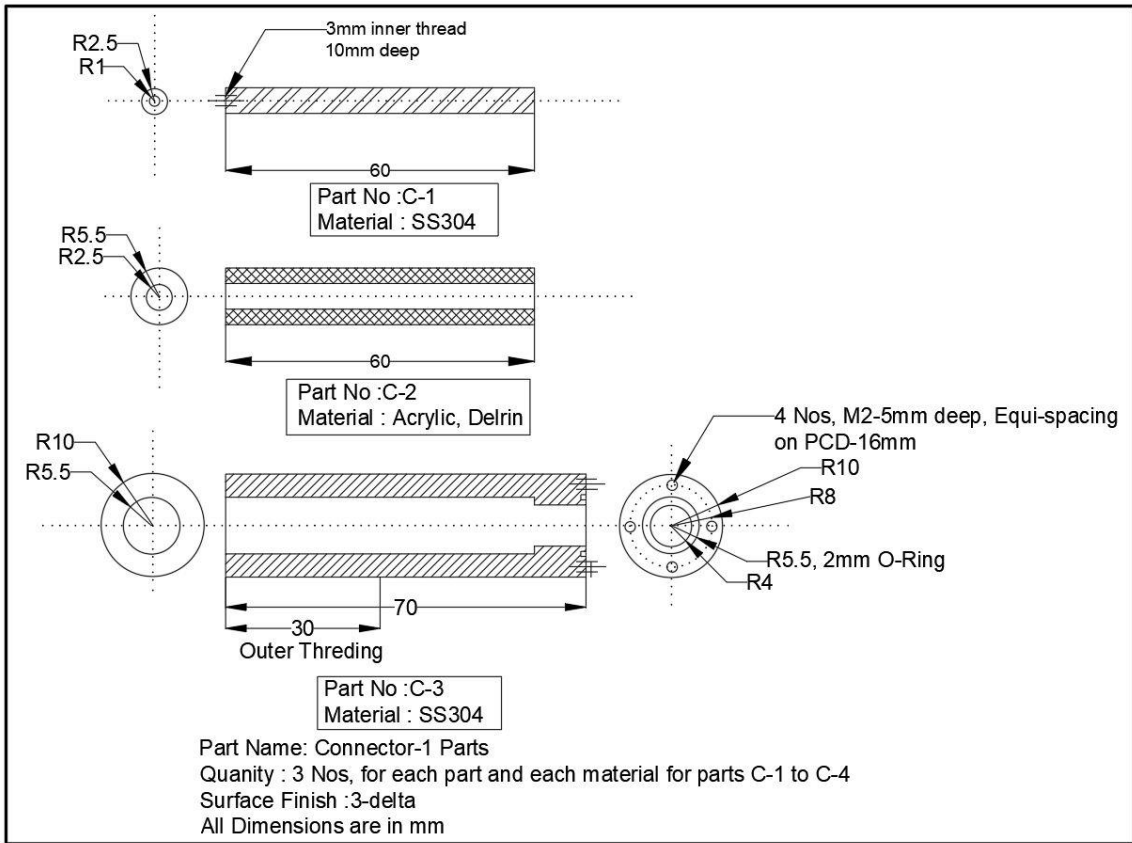

Figure-18: Connector-1 Parts

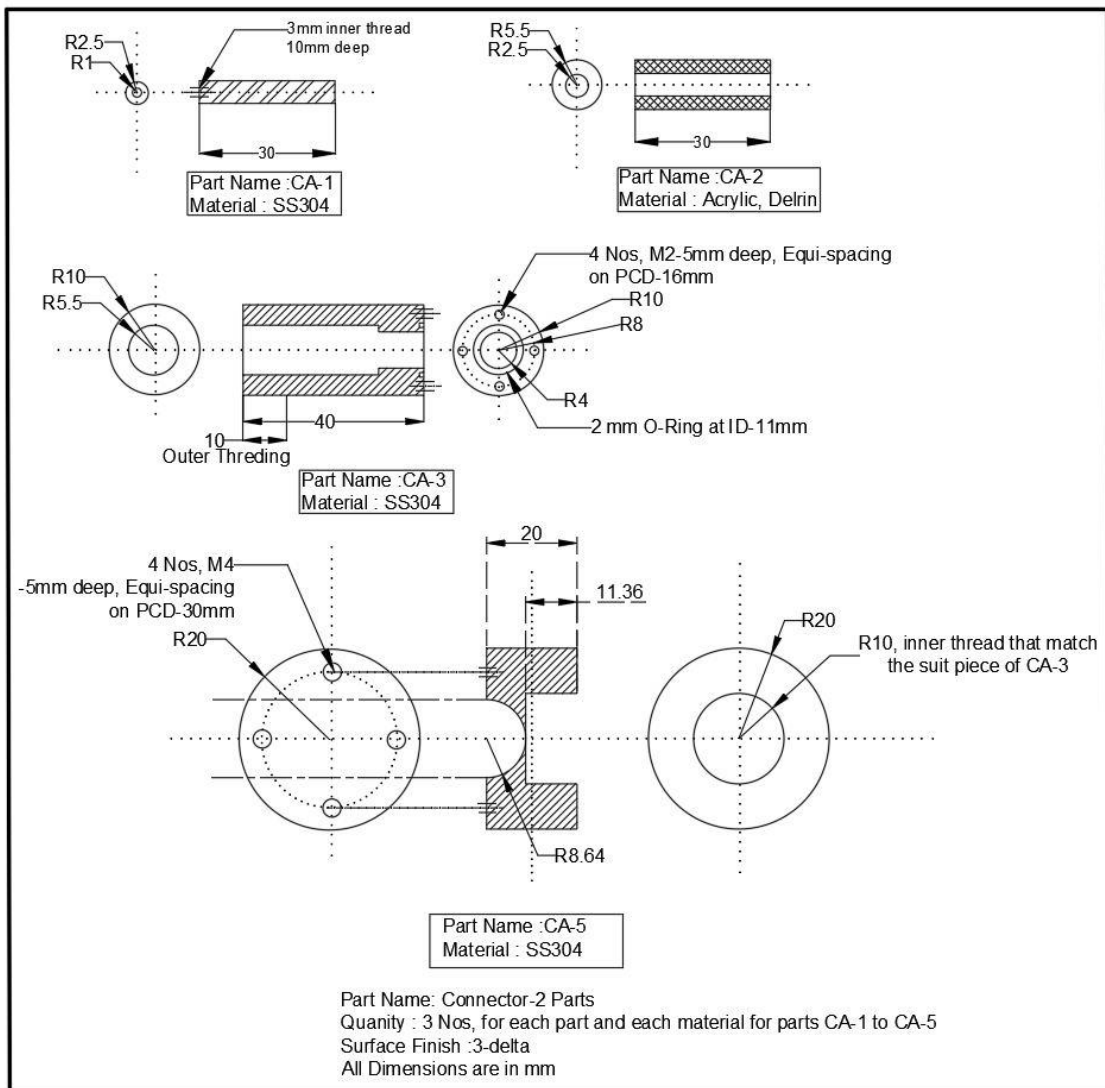

Figure-19: Connector-2 Parts

Instructions for switch assembly and testing:

1. Finishing for all the materials after fabrication must be done.
2. Proper SS Allen key nuts and bolts with washers must be used while assembling the switch. All sizes Allen key nuts and bolts with washers of 20Nos as spare must be provided.
3. O-rings must be installed at the specified dimensions in the drawing. All sizes O-rings of 5Nos as spare must be provided.
4. Standard KF 50 flange and flange (a) should be welded at the specified dimensions of the switch on ground electrode.
5. The switch assembly must be tested to vacuum of 10^{-4} Torr at the vendor's site. The leak rate should be $\sim 10^{-9}$ mbar lts/s. During testing, dummy connector can be used after fitting the nozzles in ground electrode to seal the chamber.

****NOTE:**

- a) Minor changes in the fabrication may occur. The extra charges will not be paid to vendor.
- b) Maximum variation of 5% for ≤ 50 mm and 2% for above 50mm in the dimensions during fabrication are to be accepted for technical optimization.

Annexure-II (Ref: BARC(V)/PP&EMD/2021-22/R&D-44/WO/RS/66)

General Terms and Conditions

1. Quantity surveillance, inspection and inspection report

- 1.1. All work covered by the inspections shall be subjected to quality surveillance by the purchaser or his authorized representatives for which purpose the fabricator shall allow access at all reasonable times during manufacture to.
- 1.2. The premises in which the work is being carried out.
- 1.3. The drawings and or tooling involved.
- 1.4. Gauges, instruments etc. required for inspecting the work.
- 1.5. Inspection and tests shall be carried out by the fabricator as per the requirements detailed in the drawings and the specifications.
- 1.6. The fabricator shall submit inspection reports to the purchaser for approval
- 1.7. Components found unsatisfactory as to workmanship or material shall be removed by the fabricator and replaced by the components which is satisfactory.
- 1.8. The finished components shall not be dispatched prior to approval by our Engineer.

2. Raw Material

- 2.1. Raw Material for all the components and hardware will be provided by the supplier.

3. Delivery

- 3.1. The contractor shall deliver the finished components after approval of our Engineer **on or before 6 weeks from the date of work order** to BARC, Visakhapatnam.
- 3.2. In case any extension in delivery is to be granted to the contractor, party shall make a written request for extension justifying the reasons.

4. Sub Contract

- 4.1. The fabricator shall not sub-contract any or all the work without written consent from the purchaser. The fabricator shall be responsible to the purchaser for all of the sub contractor of the fabricator, if at all allowed by the purchaser.

5. Taxes

- 5.1. GST @5% or as applicable, against undertaking attached as Annexure-III from the supplier.

6. Payment

- 6.1. Payment will be made within one month only after satisfactory completion of work and on production of invoice with details of location of supply, separate tax components along with PAN & GSTN, advance stamped receipt (Annexure-IV), 4 nos. of One year Guarantee/ Warranty Certificates, Bank details & receipt and issue of material from store.**
- 6.2. Advance / Part payment or against delivery cannot be made.**
- 6.3. It may be noted that Income Tax at 2% will be deducted from your bill.**
- 6.4. TDS is to be deducted at the rate of 2% on payments made to the supplier of taxable goods and/or services, where the total value of such supply, under an individual contract, exceeds two lakh fifty thousand rupees.**
- 6.5. Any delay which is attributable to the contractor is liable for penalty @ 1/2% per week (max 5%) to be imposed on the contractor.**

7. Confidentiality

- 7.1. No party shall disclose any information to third party concerning the matters under this contract generally. In particular, any information identified as "PROPRIETARY" in nature by the disclosing party shall be kept strictly confidential by the receiving party and shall not be disclosed to any third party without the prior written consent of the original disclosing party.
- 7.2. "RESTRICTED INFORMATION" categories under section 18 of the Atomic Energy Act, 1962 and "OFFICIAL SECRETS" under section 5 of the Official Secrets Act, 1923:-
- 7.3. Any contravention of the above mentioned provisions by any contractor, sub-contractor, consultant, advisor or the any employees of a contractor will invite penal consequences under the aforesaid legislation.
- 7.4. Prohibition against use of BARC's name without permission for publicity purpose:-
- 7.5. The contractor or sub-contractor, consultant, advisor or the employees engaged by the contractor shall not use BARC's name for publicity through any public media like press, radio, T.V., or internet without the prior written approval from BARC (vide circular ref: 2/Misc-9/Lg1/2001/92 dated April 30, 2001).

Dr. Rohit Shukla, SO – G,
Officer-in-charge, Diagnostics and Applications Group,
PP&EMD, BARC, Visakhapatnam
Contact: 0891-2832010
Email: rshukla@barc.gov.in

Dr. (Smt.) Archana Sharma
OS/Director, BTDG
BARC, Mumbai

UNDERTAKING
(Goods & Service Tax)

The Following certificates should be submitted by the suppliers/contractors to the paying authority on the bills itself when Goods & Servant Tax (GST) is claimed as extra by the contractors/suppliers.

1. **Certified that** the goods and packing on which Goods & Service Tax (GST) has been charged have not been exempted under the Goods & Service Tax (GST) or the rules made there under.

2. **Certified further that** we have actually paid Goods & Service Tax (GST) and are being assessed to Goods & Service Tax (GST) and also that where there are statutory exemptions under the GST act concerned we have availed of the same and certify non-availability of such provisions for Goods & Service Tax (GST).

3. **Certified that** in respect of the amount claimed in the bill, no claim is pending for refund/ or is admissible. Certified that in the event of our getting refund in whole or in part of the element of Goods & Service Tax (GST), we shall pass on the benefit of the amount of refund obtained by us.

4. **Certified further that** we (our branch or agent) _____

(Address) _____

are registered as dealer in the State of _____ under the
Central Registration No. _____ for the
purpose of Goods & Service Tax (GST)

Signature & Stamp

भाभा परमाणु अनुसंधान केंद्र (भापअ केंद्र), ट्रॉम्बे, मुंबई-400085
BHABHA ATOMIC RESEARCH CENTRE (BARC), TROMBAY, MUMBAI-400085

भुगतान के लिए प्रस्तावित विकल्प
OPTION FOR PAYMENT WITH PRE-STAMPED RECEIPT

भुगतान एवं लेखा अधिकारी, भापअ केंद्र, ट्रॉम्बे, मुंबई-400085 से रु. Received Rs.
 (रुपये Rupees.....) only मात्र
 from Pay & Accounts Officer, B.A.R.C., Trombay, Mumbai-400085 on account of
 हेतु प्राप्त किये।

दावेदार का नाम (कर्मचारी के मामले में, कृपया अपनी कर्मचारी संख्या एवं सीसी संख्या भी लिखें) Name of Claimant (In case of employee, pl. write your Emp.No & CC No. also)			
संपर्क फोन नं. Contact Number		दावे का स्वरूप एवं दावा संख्या Nature of claim and Claim No	
दावेदार/कर्मचारी के हस्ताक्षर (गुणस्व टिकट पर, यदि आवश्यक हो तो) Signature of Claimant/ employee (on Revenue Stamp, if required)			

भुगतान प्राप्त करने हेतु विकल्प OPTION FOR RECEIVING PAYMENTS

कर्मचारियों, पेंशनभोगियों, गैर-सरकारी व्यक्तियों, ठेकेदारों एवं सप्लायरों के लिए

FOR PAYMENTS TO EMPLOYEES, PENSIONERS, NON-OFFICIALS, CONTRACTORS AND SUPPLIERS

(कृपया ध्यानपूर्वक पढ़ें तथा उपयुक्त खाने में x अंकित करके (क) या (ख) या (ग) या (घ) में से किसी एक विकल्प का चयन करें)

(Please read carefully and choose one option either (A) or (B) or (C) or (D) for payment by marking x in the box suitable to you)

(क) भारतीय स्टेट बैंक (एसबीआई) की कोर बैंकिंग सेवा (सीबीएस) शाखा में मेरा/हमारा खाता है जिसका ब्योरा निम्नवत है:
(A) I/We have Account in a Core Banking Service (CBS) branch of State Bank of India (SBI) as per the details given below:

1. एसबीआई शाखा का नाम एवं कोड Name & Code of branch of SBI	
2. खाता संख्या Account Number	
3. खाते का नाम Account Name	
4. क्या ब्योरों के सत्यापन हेतु अद्यतन चेक लीफ संलग्न है? Whether a copy of latest cheque leaf is enclosed for verification of the details.	

(ख) भारतीय स्टेट बैंक के अलावा केवल आरटीएस/एनईएफटी सुविधा वाली शाखा में मेरा/हमारा खाता है:
(B) I/We have Account in a RTGS/NEFT enabled branch of a Bank other than State Bank of India (SBI) as per the details given below

1. बैंक का नाम Name of Bank		2. बैंक की शाखा का नाम Name of branch of Bank	
3. खाता संख्या Account Number			
4. खाते का नाम Account Name			
5. आरटीएस/एनईएफटी के लिए एफएस कोड (मुख्यतः ई-प्राप्ति के लिए) IFS Code for RTGS/NEFT (mainly e-receipt)			
6. क्या ब्योरों के सत्यापन हेतु अद्यतन चेक लीफ संलग्न है? Whether a copy of latest cheque leaf is enclosed for verification of the details			

संबंधित भुगतान अनुभाग द्वारा दावेदार/कर्मचारी का सत्यापन-

VERIFICATION BY THE PAY SECTION CONCERNED OF THE CLAIMANT / EMPLOYEE

मैंने उपरोक्त विकल्प (क) * या (ख) * में दिए गए व्योरे का व्यक्तिगत रूप से सत्यापन किया है एवं संलग्न अद्यतन चेक लीफ की प्रति के अनुसार सही पाया।

I have personally verified the details given in option (A)* or (B)* above and the same are found true and correct as per the copy of latest cheque leaf enclosed.

* जो लागू न हो उसे काट दें। *Strike out whichever is not applicable.

सहायक लेखा अधिकारी Assistant Accounts Officer
(.....अनुभाग Section), भापअ केंद्र BARC

(A) केवल निम्नलिखित स्थानीय भुगतान विभागों के लिए
(A) ONLY FOR LOCAL PAYMENT SBI BRANCHES

भारतीय स्टेट बैंक (एसबीआई) की कोर बैंकिंग सेवा (सीबीएस) या अन्य आरटीएस/एनईएफटी सुविधा वाली बैंक में भेज/हमारा खाता नहीं है। अतः मैं/हम अनुरोध करता हूँ / करते हैं कि निम्नलिखित चेक द्वारा भुगतान करें। मैं/हम निम्नलिखित में से किसी एक प्रकार का चेक सुपुर्दगी अपत्राज चाहते हैं। (लाभ खाने में टिक मार्क किया जाए)

I/We do not have Account in a Core Banking Service (CBS) branch of State Bank of India (SBI) or other RTGS/NRFT enabled Bank.

I/we, therefore, request you to make payment by local Cheque. I/We would like to choose the mode of delivery of cheque one of the given below. (TO BE TICK MARKED IN APPLICABLE BOX).

1.	मैं/हम चेक अनुभाग, भापअ केंद्र (केवल कर्मचारियों के लिए लागू) से चेक लेंगे I/we will collect the cheque from Cheque Section, BARC (For employees only)	
2.	कृपया चेक निम्नलिखित ठेका पते पर भेज दें (जो कर्मचारी नहीं हैं उनके लिए) Please send the cheque by post at the full postal address given below (For other than employees)	

(B) भारतीय स्टेट बैंक (एसबीआई) की कोर बैंकिंग सेवा (सीबीएस) या अन्य आरटीएस/एनईएफटी सुविधा वाली बैंक में खाता भेज/हमारा नहीं है। अतः मैं/हम अनुरोध करता हूँ / करते हैं कि निम्नलिखित व्योरे के अनुसार डिमांड ड्राफ्ट द्वारा भुगतान करें (यदि विकल्प (क) या (ख) लागू नहीं हो तो, केवल बाहर के स्थान पर डिमांड ड्राफ्ट द्वारा भुगतान के लिए)।
(B) I/We do not have Account in a Core Banking Service (CBS) branch of State Bank of India (SBI) or other RTGS/NRFT enabled Bank. I/we, therefore, request you to make payment by Demand Draft (for outstation payments only if option (A) or (B) not applicable) as per the information given below:

भारतीय स्टेट बैंक (एसबीआई) की कोर बैंकिंग सेवा (सीबीएस) या अन्य आरटीएस/एनईएफटी सुविधा वाली बैंक में खाता भेज/हमारा नहीं है। अतः मैं/हम अनुरोध करता हूँ / करते हैं कि निम्नलिखित व्योरे के अनुसार डिमांड ड्राफ्ट द्वारा भुगतान करें (यदि विकल्प (क) या (ख) लागू नहीं हो तो, केवल बाहर के स्थान पर डिमांड ड्राफ्ट द्वारा भुगतान के लिए)।

I/We do not have Account in a Core Banking Service (CBS) branch of State Bank of India (SBI) or other RTGS/NRFT enabled Bank. I/we, therefore, request you to make payment by Demand Draft (for outstation payments only if option (A) or (B) not applicable) as per the information given below:

1.	एसबीआई की निकटतम शाखा का नाम व कोड Name and Code of nearest branch of SBI	
2.	डी.डी. के प्रेषण हेतु दावेदार का पूरा ठेका पता Full postal address of claimant for dispatch of D.D.	

टिप्पणी: मैं/हम बैंक की ओर से अथवा डाक के कारण, जैसा भी मामला हो, भुगतान में होने वाले विलंब हेतु भुगतान एवं लेखा अधिकारी, भापअ केंद्र को जिम्मेदार नहीं ठहराएंगे। मैंने विकल्प (क)* अथवा (ख)*, जैसा भी मामला हो, में दिए गए विकल्पों का सत्यापन, भापअ केंद्र के संबंधित अनुभाग द्वारा किए जाने हेतु चेक लीफ की एक अद्यतन प्रतिलिपि इसके साथ संलग्न कर दी है।

* जो लागू न हो उसे काट दें।

NB: I/We WILL NOT HOLD P&AO, BARC RESPONSIBLE FOR ANY DELAY IN TRANSMITTING THE PAYMENT BY BANK OR FOR POSTAL DELAY, AS THE CASE MAY BE. I HAVE ENCLOSED A COPY OF LATEST CHEQUE LEAF FOR VERIFICATION OF THE DETAILS GIVEN IN OPTION (A)* OR (B)*, AS THE CASE MAY BE, BY THE SECTION CONCERNED OF BARC.

*Strike out whichever is not applicable.

दावेदार/कर्मचारी के हस्ताक्षर Signature of Claimant / Employee
ई-मेल आई.डी./E_mail ID.