

Government of India
BHABHA ATOMIC RESEARCH CENTRE
Atomic Fuels Division

Ref. No.: AFD/FAS/18/220657

Nov 19 , 2018

Sub: Fabrication and Supply of Aluminium components (Tie Plates) as per attached drawing and specification

Dear Sir/ Madam,

For & on behalf of The President of India your sealed offer, on printed letter head of your company, is invited for "Fabrication and Supply of Aluminum components (Tie Plates) as per drawing and Specification", using Aluminium AA 5052 grade. The Drawing, material specification, technical and general terms & conditions are attached herewith.

Your offer in sealed envelope bearing title "Fabrication and Supply of Aluminum components (Tie Plates) as per drawing and Specification", above reference no. & due date 7/12/2018, should be sent to following address, so as to reach on or before 7/12/2018, by registered / speed post only.

R K Srivastava
Atomic Fuels Division
Bhabha Atomic Research Centre
Trombay, Mumbai - 400 085.

Courier or Hand delivery of quotation is not acceptable.

(R K Srivastava)
FAS,AFD

(Amit Sharma)
SO/F, AFD

(Rakesh Kumar)
Head,FAS, AFD
For & on behalf of President of India

Encl: 1 Specification of Material.
2. Drawing of component.

Technical Terms and condition

1. Scope of work:

- 1.1 Supply of Aluminium components as per Drawing and Specification.
- 1.2 **Quantity:** 2250 nos.
- 1.3 **Material:** AA5052 grade Al as per attached specification. Vendor, who is not an Al Extruder, shall purchase the material of suitable size from a reputed Al Extruder and shall submit a copy of Purchase Order placed with the Extruder and Material Test Reports confirming to the specification of material to the purchaser (ie. BARC). Vendor, who is an Aluminum Extruder, shall cast and extrude rods of suitable size and shall submit only Material Test Report confirming to the spec of material, to the purchaser (ie. BARC).
The Material Test Report must contain cast no, total weight cast, and corresponding chemical analysis report etc to verify the material properly at any stage of production schedule.
Machining of components shall be started only after clearance of material by the representative of Purchaser (BARC)
- 1.4 **Work completion time:** 6 months from the date of placement of Work Order.
- 1.5 **Inspection Report:** Each finished component shall be laser marked. **Dimensional Inspection of each finished component shall be done as per drawing and inspection report indicating the observed values (mere writing "ok" is not acceptable) shall be submitted with components. Deviation(s) observed shall be clearly highlighted in the report being submitted.** Purchaser reserves the right to inspect part or all components at its works. In case of any dispute, inspection report prepared by QC personnel of purchaser shall be considered final.
- 1.6 **Cleaning & Packaging:** The machined components shall be cleaned so that no dirt, grease or any other stains are present on the surface before final packing. Each finished component shall be wrapped in bubble sheet individually with identification number as per inspection report. The components thus packed shall be placed in a suitable wooden box. Not more than 200 components shall be packed in one box.
- 1.7 **ISO Certificate:** Vendor should also have valid ISO 9001 or equivalent certification. Vendor should submit the copy of ISO certificate along with the quotation. **Quotation without valid ISO certificate will be rejected.**
- 1.8 **Samples before starting bulk machining:** After clearance of material, the vendor shall submit 10 samples. The bulk machining shall be started only after clearance from purchaser about their dimensional accuracies.
- 1.9 The material cleared by the purchaser should be stored properly to avoid mix up with other materials.

2. General Terms & Conditions:

- 2.1 A variation of $\pm 5\%$ in the final quantity is acceptable. Payment will be made only for accepted components. The amount for the rejected pieces will be deducted as per the rates quoted by vendor for finished components. The rejected pieces will not be returned back to vendor.
- 2.2 All work pertaining to machining and inspection shall be performed by the vendor and no help or assistance of any sort shall be extended from purchaser's side.
- 2.3 For any clarification regarding the specifications and to assess the scope of work involved, you may contact Mr. R K Srivastava (Tel. 022 2559 4968, email: rohitks@barc.gov.in) during office hours (10. am to 6.0 pm, Monday to Friday, except holidays).
- 2.4 Quotations shall clearly mention the rate for fabrication of 1 no. of component. Consolidated offers giving total cost shall be summarily rejected.
- 2.5 **GST @ 5% shall be specified separately apart from the base cost. GST exemption certificate will be supplied by the purchaser, ie., BARC.**
- 2.6 Validity of offer (min 90 days) and work completion period shall be clearly mentioned in the offer letter.
- 2.7 Income tax @ 2% of amount of bill and surcharge on IT as applicable shall be deducted at source. Education cess @ 3 % on IT & surcharge will also be deducted from the supplier's bill.
- 2.8 Quotations are to be on printed letter head / quotation format which should consist of registered GST Number, PAN of the firm etc
- 2.9 **Quotation is to be sent by Registered / Speed Post only.** Quotations that are received by, courier, email, fax, any other computer generated form without signature, handwritten etc shall be considered as invalid & rejected.
- 2.10 Payment will be arranged after satisfactory completion of work and on submission of following documents
 - i. Bills in Triplicate
 - ii. Delivery challan in duplicate.
 - iii. Advanced stamped receipt.
 - iv. GST undertaking (format of GST undertaking will be sent by purchaser along with work order).**Advance or Payment against Part delivery is not permissible in any case.**
- 2.11 Vendor may fill up form of option for payment through ECS/RTGS with pre-stamped receipt at the time of payment.
- 2.12 Any delay in delivery which is attributed to the supplier is liable for penalty @ $\frac{1}{2}$ % per week (Max 5%) which will be imposed on supplier.

3. Confidentiality Clause

I. Confidentiality:-

No party shall disclose any information to any third party concerning the matters under this contract generally. In particular, any information identified as "Proprietary" in nature by the disclosing party shall be kept strictly confidentially by the receiving party and shall not be disclosed to any third party without the prior written consent of the original disclosing party.

This clause shall apply to the sub-contractors, consultants, advisers or the employees engaged by a party with equal force.

II. **“Restricted information” categories under Section 18 of the Atomic Energy Act 1962 and “Official Secrets” under Section 5 of the Official Secrets Act 1923. :-**

Any contravention of the above-mentioned provisions by any contractor, sub-contractor, consultant adviser or the employees of a contractor will invite penal consequences under the aforesaid legislation.

III. **Prohibition against use of BARC’s name without permission for publicity purposes.**

The contractor or sub-contractor, consultant, adviser or the employees engaged by the contractor shall not use BARC’s name for any publicity purpose through any public media like Press, T.V. or Internet without the prior written approval of BARC.

(R K Srivastava)
FAS, AFD

(Amit Sharma)
SO/F, AFD

(Rakesh Kumar)
Head, FAS, AFD
For & on behalf of President of India

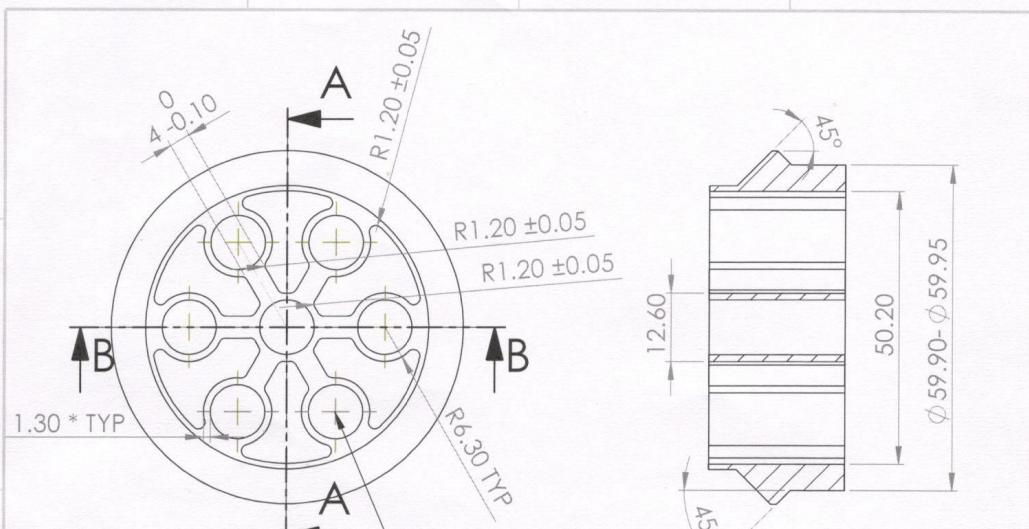

6 $\phi 10$ Through Holes on 36 ± 0.1 PCD and one at centre as shown

SECTION A-A

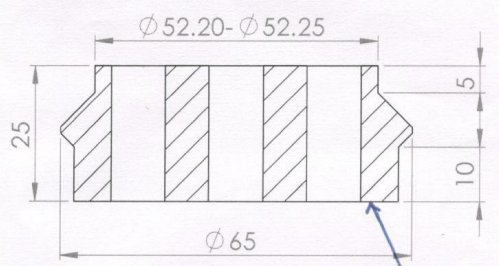

SECTION B-B

Laser Mark

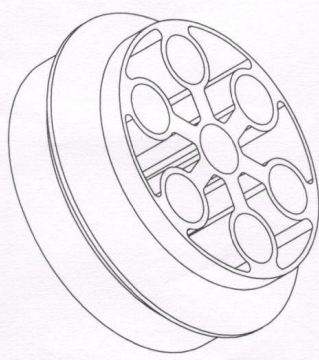

Notes:

1. General tolerance ± 0.2 mm on length and ± 0.1 mm on diameter.
2. All sharp corners shall be rounded off to suitable radius.
3. All dimensions are in mm.
4. * Marked thickness should be more than 1mm.

5.) *LASER MARKING SIZE - 4 mm, Font. Arial*