

BHABHA ATOMIC RESEARCH CENTRE  
RADIOCHEMISTRY DIVISION

Ref:RCD/PM/2018/OPA/ 219242

15-11-2018

**Sub: Minor fabrication of Instrument cabinet and related accessories**

Quotations are invited for the fabrication for **Instrument cabinet and related accessories**. The setup will house standard power supply, NIM bin and other various instrument controls. The detailed specifications and terms and conditions are as per enclosed annexure I and II.

Quantity: As per annexure II.

Your sealed quotation **super-scribing the Enquiry reference number and subject**, addressed to **Head, Radiochemistry Division, BARC**, Mumbai 400 085 and special attention to **Priya Maheshwari** should reach on or before **07<sup>th</sup> December, 2018** by **Registered Post or Indian Govt Speed Post** and it will be opened on the following date. The quote should show PAN number, VAT number, Service Tax registration number, Name and address of the bank, Account number, IFS code and MICR No. of the concerned vendor. For further technical query, you may email [priyam@barc.gov.in](mailto:priyam@barc.gov.in).

(Priya Maheshwari)  
Scientific Officer (E)  
RCD, BARC

Enclosure: (1) Annexure 1  
(2) Annexure 2

## ANNEXURE 1

### 1. **Scope Of Work:**

Minor fabrication of Instrument cabinet and related accessories

### 2. **Specification:**

The drawing of the **Instrument cabinet and related accessories** is attached herewith (**annexure II**).

### 3. **Payment:**

- (a) 100% by payment will be made ONLY through ECS after the satisfactory completion of work.
- (b) Payment will be released on receipt of the bill duly certified by user department, indicating the service contract number, PAN number, VAT number, Service Tax registration number, Name and address of the bank, Account number, IFS code and MICR No. which appears on the cheque leaf, of the party.

### 4. **COMPLETION REPORT:** A completion report may please be forwarded to this office with a copy to the user department after completion of work, but well before the expiry of the contract, certifying that the equipment has been upgraded as per the terms and conditions of the contract and also with your proposal for extension of the work order, if any, indicating our work order No. and date for our consideration.

5. Please ensure that our work order No. is quoted in all correspondence and bill etc.

6. Kindly acknowledge receipt and confirm that the work order will be carried out in terms of the work order.

### 7. **Inspection:**

The purchaser shall have free access at all possible times to all shop where material is being fabricated and assembled and all reasonable facilities for such inspection shall be provided. Approval from our inspecting engineer should be obtained prior to completion of work.

### 8. **Confidentiality Clause:**

- a. Confidentiality: No party shall disclose any information to any third party concerning the matter under this contract. In particular any information identified as '**Proprietary**' in nature by the disclosing party shall be kept strictly confidential by the receiving party and shall not be disclosed to any third party without the prior written consent of the original disclosing party.
- b. "Restricted information " categories under section 18 of the Atomic Energy Act 1962 and 'Official secrets' under section 5 of the official secrets act 1923: Any contravention of the above mentioned provision by any contractor, adviser or employee of the contractor will invite penal consequences under the aforesaid legislation.
- c. Prohibition against use of 'BARC's name without permission for publicity purpose: The contractor or subcontractor, consultant, adviser or employee

engaged by the contractor shall not use the name of the BARC for any publicity purpose through any media like press, Radio, TV or Internet without the prior written approval of BARC.

**9. Terms and Conditions:**

1. Payment will be made after satisfactory completion of the work and on production of bill, advance stamped receipt and certificate of guarantee for workmanship.
2. Entire Job will be completed within **30 days** from the receipt of the work order and acceptance in writing by the firm.
3. The supplier should have working staff holding valid PVC who may be permitted within BARC for carrying out work connected with the work order.
4. Income Tax at 2% will be deducted from your Bill.
5. Any delay which is attributed to the contractor is liable for penalty @ $\frac{1}{2}$ % per week (Max. 5%) to be imposed to the contractor.

## ANNEXURE –II

### Technical Specification for Tender No. RCD/PM/2018/OPA/65174

#### **Job Description:**

The job involves fabrication of Instrument cabinet and related accessories. The cabinet will house various power supplies, NIM bins and various instrument control units. The frame of the cabinet will be made of extruded aluminum. The front, back and side doors should be detachable. The cabinet is meant to be resting on lockable castor wheels.

The detail description of each component is tabulated as follows:

**Table 1.**

Serial Number	Component	Specifications	Number
1.	<b>Instrument Cabinet</b>	<ul style="list-style-type: none"><li>• HEIGHT = 42U</li><li>• It consists of 2 aluminium alloy frameworks consisting of 4 vertical and 4 horizontal sections bolted together with 4 depth sections to form a structure</li><li>• It will also have 1 Top Cover and 1 Bottom Cover with gland plate and rubber grommets for cable entry provisions.</li><li>• There will be 8 corner brackets to hold the whole structure together.</li><li>• The width of the cabinet will be 600 mm and the depth will be 650 mm</li></ul> <ol style="list-style-type: none"><li>1. Robust frame structure made of aluminum alloy with powder coating.</li><li>2. Top cover made of CRCA sheet with powder coated.</li><li>3. Top gland cover plate made of CRCA sheet with powder coated.</li><li>4. Bottom cover made of CRCA sheet with powder coated.</li><li>5. Bottom gland cover plate made of CRCA sheet with powder coated.</li><li>6. Recess mounting angle made CRCA sheet with powder coated.</li><li>7. Depth Support channel made of CRCA sheet with powder coated.</li><li>8. Corner Bracket made of CRCA sheet with powder coated</li></ol>	2

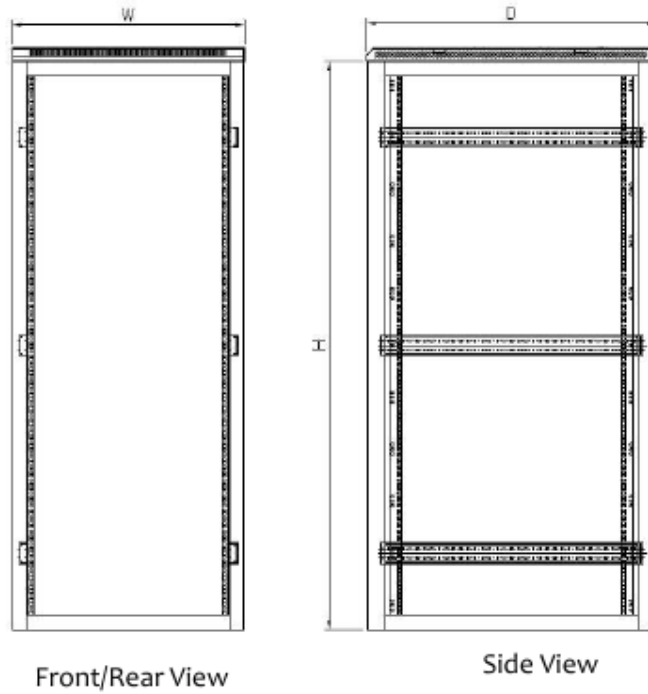
		<ul style="list-style-type: none"> <li>Detailed drawing shown in Fig 1.</li> </ul>	
2.	Front door	<ul style="list-style-type: none"> <li>Demountable</li> <li>Perforated</li> <li>Size= 36U - 600W</li> <li>Cam Lock</li> <li>Ventilation - Black Fine Tex.</li> </ul>	2
3.	Rear Door	<ul style="list-style-type: none"> <li>Demountable</li> <li>Perforated</li> <li>Size= 36U - 600W</li> <li>Cam Lock Ventilation - Black Fine Tex.</li> </ul>	2
4.	Side panels	<ul style="list-style-type: none"> <li>Side panels are to be made up of CRCA sheet and powder coated</li> <li>They should have slam latches for easy removal and fitment onto the rack.</li> </ul>	4
5.	Fan Module	2U size, with temperature controller	4
6.	Cable manager -I	Horizontally mounted; Width=482.6 mm, height= 43.5 mm	4
7.	Cable manager -II	Width=50mm, height= 800 mm	4
8.	Cable manager - III	Width=50mm, height= 1600 mm	4
9.	Castor wheels on which the cabinet will be resting		8 (one set of 4 wheels for each instrument cabinet)
10.	Earthing strip -I	Width = 483mm	4
11.	Earthing strip -II	width =150mm	4
12.	Support Angle	Depth = suitable for the above mentioned cabinet	50 pair
13.	Cantilever Tray	Depth = 255mm	5

14.	Monitor tray	Depth = 600 mm	10
15.	Blank Panel	1U	4
16.	Power distribution unit-I	<p>width =1062mm; height = 80 mm ; depth = 58 mm</p> <ul style="list-style-type: none"> <li>fitted with relay switch with manual reset to prevent powering On after power resumption following power out.</li> </ul>	4
17.	Power distribution unit-II	<ul style="list-style-type: none"> <li>Rated for 16 Amp;</li> <li>fitted with relay switch with manual reset to prevent powering On after power resumption following power out.</li> <li>width=482mm, Height= 80mm, Depth= 58mm</li> </ul>	4

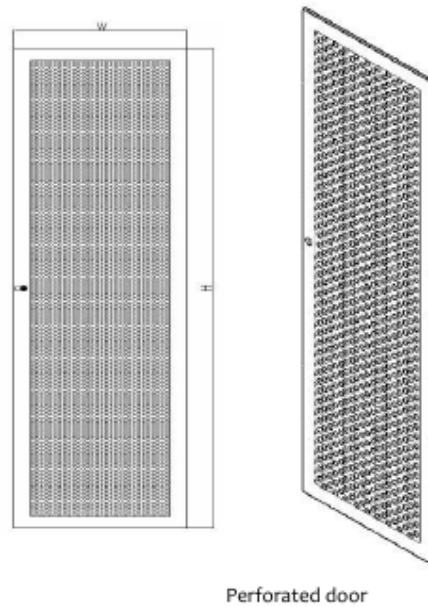
**Scope of work: Fabrication and Supply of Instrument Cabinet and related accessories as per following specifications:**

1. Fabrication and supply of instrument rack and related accessories must be done as per drawing provided. The support frame of the instrument rack should be made of extruded aluminum.
2. All the accessories mentioned above should be compatible with the instrument rack.
3. The supplier shall prepare the detailed fabrication drawings and must submit the drawing to undersigned for scrutiny before starting the fabrication.

**(Priya Maheshwari)**  
**SO (E), Radiochemistry Division**

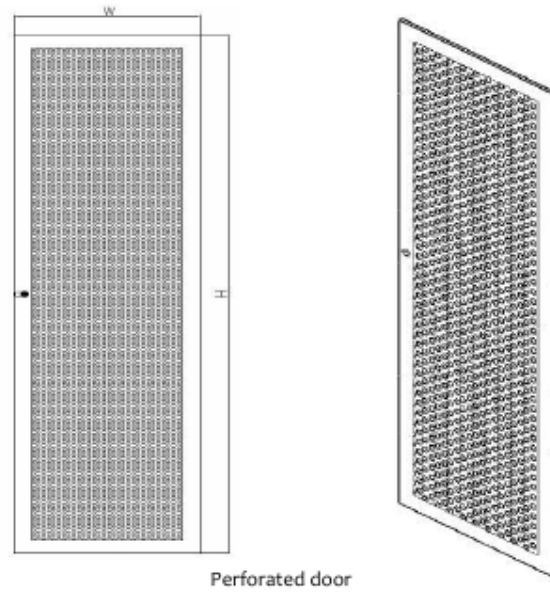


**Figure 1. Schematics of the instrument cabinet. H (overall Height suitable for 42U; W(width) = 600mm ; D(overall depth) = 650 mm;**



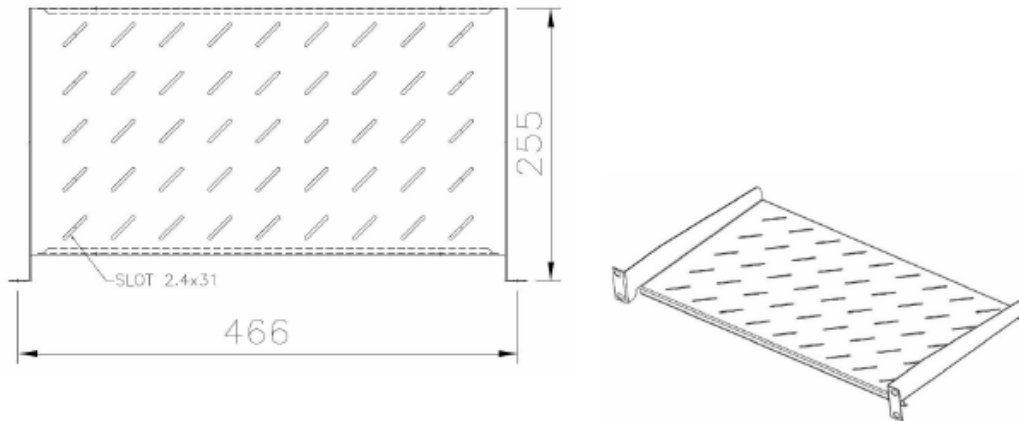
**Fig 2. Front door for instrument cabinet. It should be demountable and perforated**





Perforated door

**Fig3. Rear door for instrument cabinet. It should be perforated and demountable.**



**Fig4. Cantilever tray**