

## **Technical specifications for Fabrication and supply of high density graphite crucibles**

The requirement is for the fabrication of high density graphite crucible for experimental studies to the extent of quantity and designs specified below. The scope of the work includes

1. Procurement of high density graphite raw material as per technical specifications.
2. Fabrication of crucibles with good finish for all machined, with tolerances provided in the drawing.
3. Thorough cleaning of machined components by use of suitable acidic and organic solvent.
4. Dimensional inspection and testing as per the detailed QA/QC program.
5. Vacuum outgassing of fabricated components at 800°C to remove all volatile impurities and sealing in inert cover gas.
6. Packing and safe delivery of the fabricated components to BARC, Mumbai.

The detailed drawing of crucible, applicable standards, quantity, drawing reference and acceptance criteria are as provided in the table 1. Detailed specifications and QA plan are detailed in different subsections. All dimensions provided in the drawing are in millimeter (mm).

**Table 1. Components, applicable standards, quantity, drawing reference**

<b>S. No</b>	<b>Type of component</b>	<b>Applicable standard / Grade</b>	<b>Qty, No.</b>	<b>Drawing Ref</b>
1.	High density graphite crucibles (70cc)	ASTM D7301	4	Figure 1
2.	High density graphite crucibles (110cc)	ASTM D7301	4	Figure 2
3.	High density cylindrical crucible	ASTM D7301	12	Figure 3
4.	High density cylindrical rods	ASTM D7301	16	Figure 3

### **Technical specifications for high density graphite:**

Crystal structure: Hexagonal closed packed(HCP)  
C/2 spacing: 3.42 Å<sup>0</sup>  
Bulk Density: 1.95 - 1.97 g/cc  
Scleroscope Hardness: 68  
Purity: 99.8%  
Total impurities: 0.2%(Maximum)  
Metallic impurities: 10 ppm  
Grain size: 0.4 mm maximum  
Permeability: Helium leak tight at 10<sup>-6</sup> mm Hg

**The supplier shall also specify the following properties of the high density graphite:**

- \* Scleroscope Hardness
- \* Coefficient of thermal expansion at 3000K (a, b) and (c) directions.
- \* Thermal conductivity at 3000K (a, b) and (c) directions.
- \* Electrical resistivity

**1. Procurement of raw material and testing**

- a. Graphite, wherever mentioned in the specifications shall be as per grade specified.
- b. Certificates for material and purchase order copies for all bought out items shall be provided.

**2. Submission and approval of drawings**

- a. The contractor shall submit detailed drawings within 10 days from the date of placement of order.
- b. The drawings supplied by the purchaser are essentially design drawings. All necessary shop drawings for fabrication will have to be prepared by the contractor and submitted for purchaser's approval.
- c. The comments of purchasers in fabrication drawing shall be incorporated in the drawings. Revised drawings will be transmitted to the contractor. Approval of contractor's drawings by the department shall not relieve the contractor from the responsibility of any error or obligation or liability under the contract.

**3. Fabrication of components.**

- a. All crucibles shall be free from chips, dents, projections, surface and sub-surface crack, discontinuity of material across the thickness.
- b. The vendor shall procure all materials and bought out components as mentioned in specifications, and shall be purchased from reputed manufacturer.
- c. The fabrication of crucibles demands the highest standard of workmanship. The surfaces shall be absolutely free from steps, pits, dents, scratches.
- d. Workman ship be in accordance with high grade practice and adequate to achieve the accuracies and finishes mentioned in the drawings and the specifications to ensure satisfactory operation and service life of ports.
- e. The Supplier shall submit the complete fabrication drawing, detailed QA/QC program and the manufacturing procedures for Purchaser's approval.
- f. The materials may be cut and formed to the required shape by any process that will not unduly impair the physical properties of materials. In general, machining shall be specified in drawing and care shall be taken to ensure that chatter marks, scratches, dents are removed from machined surfaces.

**4. Cleaning of machined components**

- a. The system shall be degreased, chemically cleaned followed by cleaning with de-ionized water and dried. Then the crucibles should be baked at 1000°C for outgassing.
- b. Cleaning of material shall be in accordance with written procedures and to standards prepared by the Supplier and approved by the Purchaser.
- c. During fabrication and storage, components and subassemblies shall be protected from exposure to solutions, cleaners or other chemicals such as chlorides that may induce corrosion.
- d. During preparation of the crucibles, the material shall be protected against any physical damage which will be cause for rejection of the component during the inspection process.

## 5. Inspection, testing and acceptance criteria

- a. The contractor shall rigorously inspect the components before delivery to ensure that they will comply with the specifications and relevant drawings. The purchaser shall have access at all reasonable time to all shop where components are being fabricated/assembled and all facilities for inspection shall be provided.
- b. Each component shall undergo the following tests at supplier's shop before dispatch
  - i. Metrological inspection as per drawings
  - ii. Compliance of applicable standards

### Acceptance criteria

*The raw material shall be sampled and tested for both chemical and mechanical properties in Government approved laboratory as per the relevant ASTM standards. Testing charges have to be borne by the supplier. After inspection of workmanship and dimensions of each of the components, material shall be accepted for final delivery to BARC, Mumbai. The material which will not qualify the standards shall be rejected.*

## 6. General specifications, terms and conditions

- a. **Dimensional Tolerances:**Maximum allowable tolerance is  $\pm 0.1$ mm in all dimensions.
- b. **Quotation details:** The quotation should be in the printed letter head /quotation format which should consist of the PAN No., GST No. of the firm. Quotation shall be signed by proprietor or authorized person and affix company seal. Computer generated/scanned and printed quotation will not be accepted. Failing to mention the details in their quotation will become liable to be rejected. All taxes, other charges should be mentioned clearly.
- c. **GSTIN of BARC related details:** Suppliers please note that BARC is the final consumer of the goods/services procured and does not intends to make any outward supply. BARC will not avail the benefits of Input Tax Credit and hence, the goods can be supplied without quoting the GSTIN of BARC, Mumbai on the invoice. The invoices taxed under GST, as per rates applicable under the GST Schedule of Rates, shall be admitted for payment. An undertaking shall be submitted by the supplier that the GST has been promptly deposited with the authorities (Annexure II). GST shall be paid only in the case of supplier clearly indicating their GSTN on the invoice.
- d. **GST exemption Certificate:** Since the goods are to be supplied against the work order meant for research purpose of a research organization under DAE, the necessary GST will be exempted to the party. Interstate transaction for R&D will attract IGST only @ 5% as per notification No. 47/17-Integrated Tax (Rate) dated 14.11.2017. Transaction within the state will attract Central Goods and Service Tax (CGST) @ 2.5% as per notification no. 45/2017-Central Tax (Rate) dated

14.11.2017 and State Goods Service Tax (SGST) @2.5% as per notification no. 45/2017-State Tax (Rate) dated. 14.11.2017 of the State of Maharashtra. No claim for reimbursement of GST above the stipulated rate as per notification would be entertained later.

- e. **Material test certificates:** The material testing certificates for all raw materials shall be provided along with the items. A laboratory test certificate issued by Government approved lab conforming the purity shall also be furnished before the items are dispatched to BARC, Mumbai, India.
- f. **Note to Contractor:** All the persons involved in the erection and commissioning job, if any, shall possess valid Police Verification Certificate (PVC) to enter into BARC premises. In addition to that, vendor has to submit a certificate (Annexure I) that the contractors or their employees have not been involved in any corrupt or criminal activity and no police case has been registered against any of them. The contractor shall observe all safe working practices and shall provide safety gears to his worker wherever necessary. For any work inside BARC, the contractor has to strictly abide by rules and regulations set by Security Section of BARC, Mumbai.
- g. **Quality surveillance, inspection and inspection report**
  - i. All work covered by the specification shall be subject to quality surveillance by the purchaser or his authorized representative for which purpose the fabricator shall allow access at all reasonable time to: the premises in which the work is being carried out the drawing and/or tooling involved, and Gauges, instruments, etc. required for inspecting the work. Inspection and tests shall be carried out by the fabricator as per the requirements detailed in the drawings and the specifications.
  - ii. The purchaser reserves the right to inspect any material or equipment furnished or used by Supplier under the contract and to reject any, which is found defective in workmanship, design, or otherwise unsuitable for the purpose intended.
  - iii. Components found unsatisfactory as to workmanship or material shall be removed by fabricator and replaced by components, which are satisfactory. In the events of Purchaser's inspection revealing poor quality of goods, Purchaser shall be at liberty to specify additional procedures if required to ascertain supplier's compliance with the component specifications.
  - iv. Even though Purchaser or his representative carries out inspection, such inspection shall not however relieve Supplier from his responsibilities for furnishing the components conforming to the requirement of the contract. The Supplier shall maintain proper inspection records and make it available to Purchaser's representative whenever required. The fabricator shall submit three copies of inspection report to the purchaser for approval.
- h. **Free issue material:** There is no free issue of material. All material required for the job is to be supplied by the bidder.
- i. **Workmanship:** The surface should be free from impurities, splits, fractures and indentations, having an impact on a common processing or application of the product. Components with manufacturing defects viz. Cracks, burns, flakes, voids, inclusions, oxide scales, scratches, dirt and ingot patterns will not be accepted.

- j. **Dispatch:** The finished components shall not be dispatched prior to approval by our engineer at bidder's works.
- k. **Packing and shipment:** All components shall be packed properly to avoid damage during shipment.
- l. **Delivery schedule:** Supplier shall deliver the completed components/equipment in 30 days from the date of release of order.
- m. **Warranty:** Guarantee of the items shall be furnished for one year from the date of delivery.
- n. **Confidentiality clause:** No party shall disclose any information to any third party concerning the matters under this contract generally. In particular, any information identified as "Proprietary" in nature by the disclosing party shall be kept strictly confidential by the receiving party and shall not be disclosed to any third party without the prior written consent of the original disclosing party.  
Any contravention of the above-mentioned provisions by any contractor, sub-contractor, consultant, adviser or the employees of a contractor will invite penal consequences under the aforesaid legislation.  
The contractor or sub-contractor, consultant, adviser or the employees engaged by the contractor shall not use BARCs name for any publicity purpose through any public media like Press, Radio, TV or Internet without the prior written approval of BARC
- o. **Payment terms:** No advance payment will be made. Full payment will be made by NEFT/ECS on satisfactory completion of the works. Party should submit guarantee certificate the bill along with advance stamped receipt. Income Tax @2% will be deducted at source from the bill.

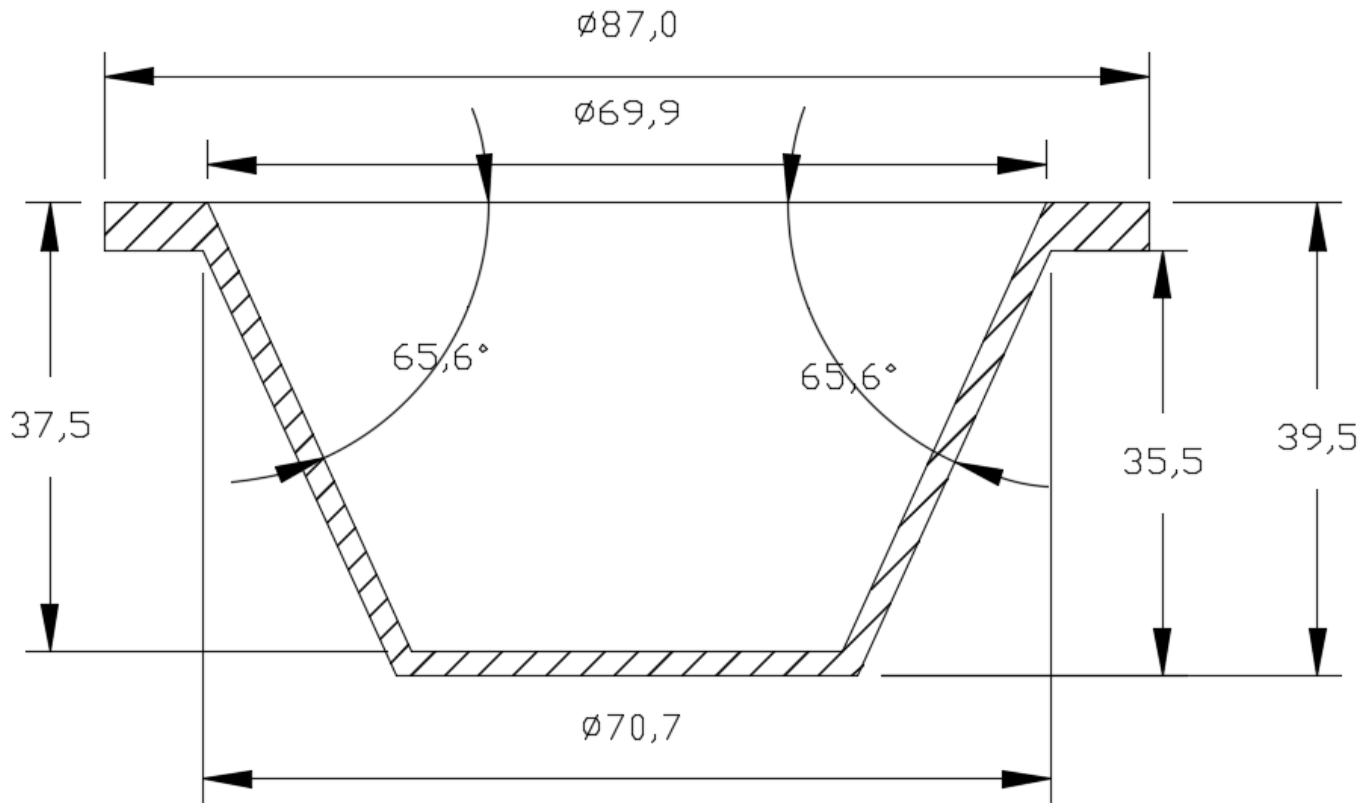

Insert for Modified EBG(G8)

Material: High Density Graphite, Quantity: 4 Nos

All dimensions in mm

Tolerance:  $\pm 0,1\text{mm}$

Figure 1: Design drawing of High Density Crucibles (70cc)

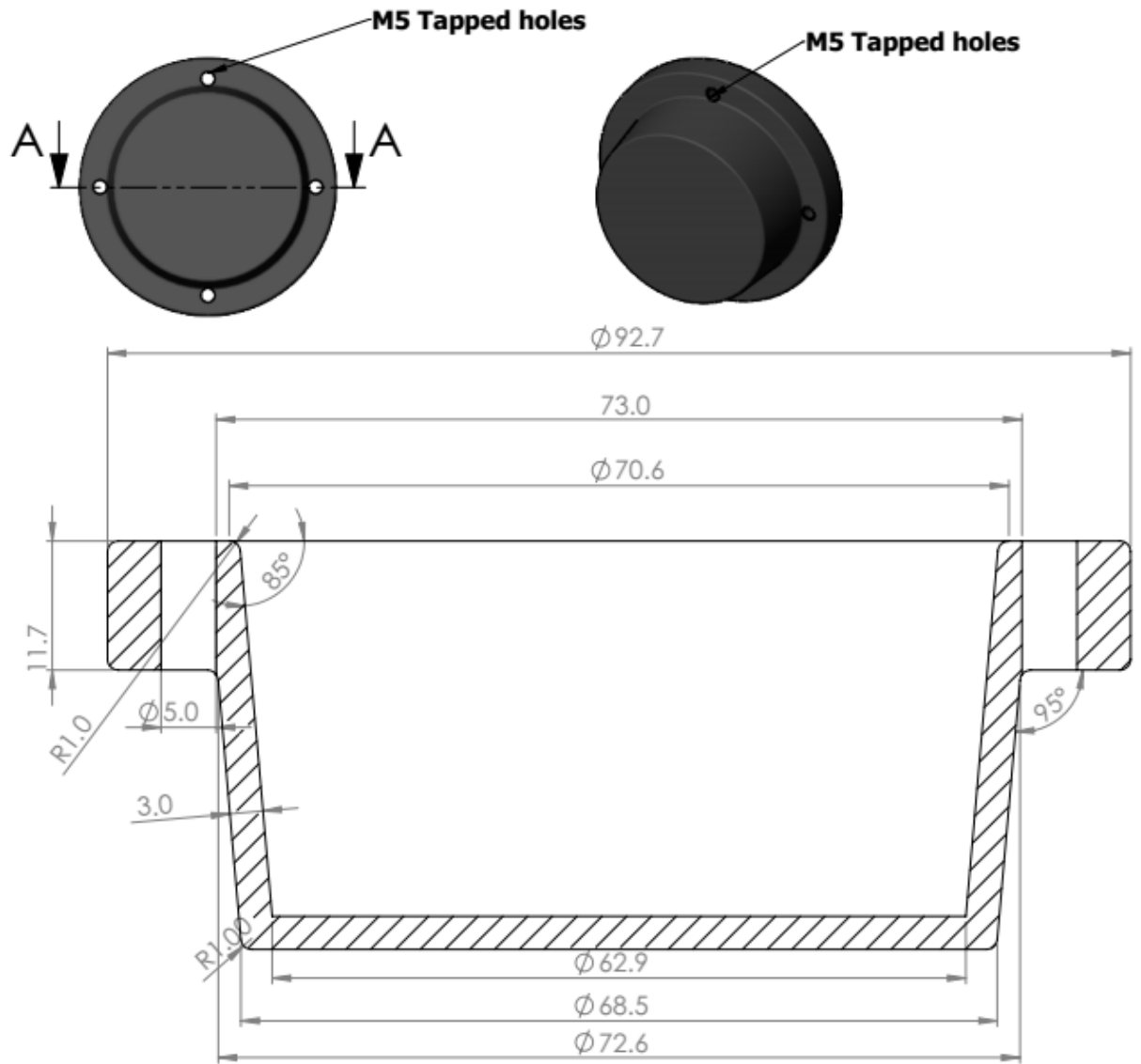

Figure 2: Design drawing of High Density Crucibles (110cc) [Tolerance  $\pm 0.1\text{mm}$ ]

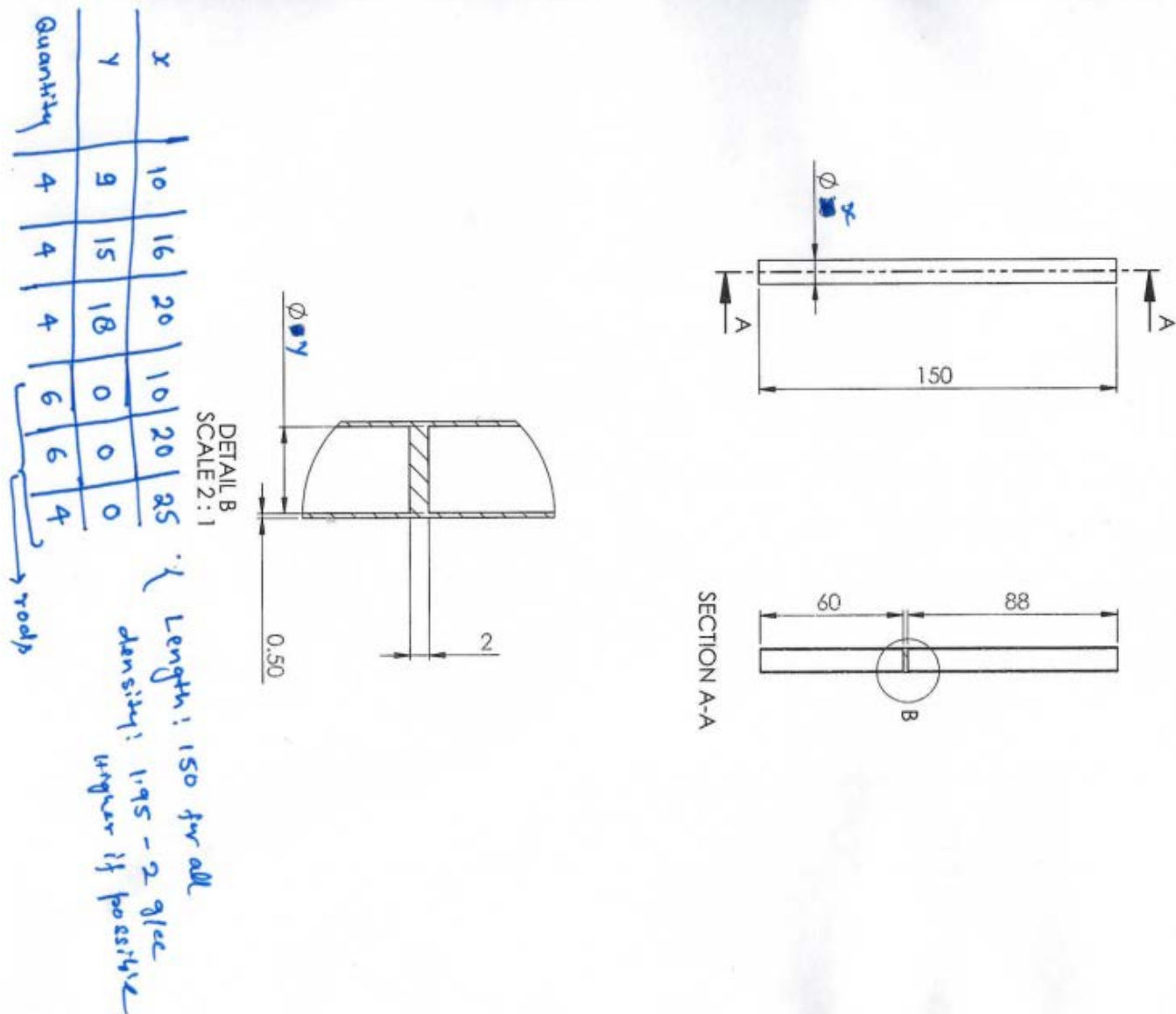

Figure 3: Cylindrical graphite crucibles and rods [Tolerance  $\pm 0.1$ mm]



**Annexure 'A'**

**Format for Quantity and Cost of proposal  
(In Rupees)**

1	2	3	4	5	6	7
SI No	Name of items	Qty	Last Purchase Price	DPS Rate	Market Survey/ Rate from Internet	Estimated Total Cost
1.	<i>High density graphite (70cc)</i>	4No(s)	-NA-	-NA-	5000/-	20000/-
2.	<i>High density graphite (110cc)</i>	4No(s)	-NA-	-NA-	5000/-	20000/-
3.	High density cylindrical crucible	12No(s)	-NA-	-NA-	1250/-	15000/-
4.	High density graphite rods	16No(s)	-NA-	-NA-	-	15000/-

Basic cost = Rs 70000/-  
Taxes, etc. = Rs 3500/-  
Transportation = Rs NIL  
Others(Testing etc) = Rs 6500/-  
Total Estimated Cost = Rs80000/-

**Note:**

1. Values in columns 4 to 6 are to be mentioned in terms of rate per unit
2. Value to be indicated in column 7 is to be derived by suitable analysis of rates mentioned in columns 4 to 6
3. Nomenclature of items to be used with details, drawing, scope of work etc. to be indicated.

**Annexure I**

**Certificate of the Contractor / Owner of the Firm**

This is to certify that the undersigned is the proprietor / Owner of M/s \_\_\_\_\_  
\_\_\_\_\_ at (address) \_\_\_\_\_

\_\_\_\_\_ who have been awarded work contract in BARC, Trombay. I hereby certify that my firm / company and my employees / labourers have not been indulge in any adverse or corrupt criminal activity and no police case has been registered against any of them.

Signature of the Contractor

Name \_\_\_\_\_

Dt \_\_\_\_\_

(Through concerned Engineer/ Officer, BARC)

To,  
Dy. Chief Security Officer  
(North/ South Zone), BARC

**UNDERTAKING**  
**(Goods & Service Tax)**

The Following certificates should be submitted by the suppliers/contractors to the paying authority on the bills itself when Goods & Servant Tax (GST) is claimed as extra by the contractors/suppliers.

1. **Certified that** the goods and packing on which Goods & Service Tax (GST) has been charged have not been exempted under the Goods & Service Tax (GST) or the rules made there under.
  
2. **Certified further that** we have actually paid Goods & Service Tax (GST) and are being assessed to Goods & Service Tax (GST) and also that where there are statutory exemptions under the GST act concerned we have availed of the same and certify non-availability of such provisions for Goods & Service Tax (GST).
  
3. **Certified that** in respect of the amount claimed in the bill, no claim is pending for refund/ or is admissible. Certified that in the event of our getting refund in whole or in part of the element of Goods & Service Tax (GST), we shall pass on the benefit of the amount of refund obtained by us.
  
4. **Certified further that** we (our branch or agent) \_\_\_\_\_  
\_\_\_\_\_  
(Address) \_\_\_\_\_  
\_\_\_\_\_  
are registered as dealer in the State of \_\_\_\_\_ under the  
Central Registration No. \_\_\_\_\_ for the  
purpose of Goods & Service Tax (GST)

**Signature & Stamp**