



Dr. Archana Sharma
Head, PPSS, APPD
arsharma@barc.gov.in



Government of India
Bhabha Atomic Research Centre
Accelerator and Pulse Power Division

Engg. Hall No.4, Trombay,
Mumbai-400085
Tele: (+9122)25590171

Ref.: BARC/APPD/VKS/2017/293

Date: 07/11/2017

Subject: Inviting quotations for fabrications of electrical circuit as per details given.

You are requested to quote for the fabrication of electrical circuit as per details given in annexure I. The circuit consists following components other than connecting leads.

S. no.	Component name	Quantity
1.	MS sheet with power coating (650 x 400 x 3) in mm	1
2.	4.7mF, 450V electrolytic capacitor	1
3.	Single phase 230V, 16A EMI filter	1
4.	MCB S210 K-16	1
5.	20Ω, 20W resistors	2
6.	Single phase 16A bridge rectifier SKB-30/16A	1
7.	Timer unit 600ST	1
8.	2 pole 25A contactor	1
9.	230V to 28V, 15V, 15V (all three 1A) transformer	1
10.	IGBT module SKM75GB128D	2
11.	100nF, 1kV snubber capacitor	1
12.	100μF, 40kHz, 10A inductor	1

1) For any clarifications the supplier can contact Sh. Ankur Patel, SO/E, APPD on any working day (Monday to Friday) on telephone Nos. 255920172 or email: aspatel@barc.gov.in.

2) Payment for the above work will be made after satisfactory completion of job and on production of bill & advanced stamped receipt along with the copy of registration. No advance payment will be made for this work. Income-tax @2% & surcharge on Income-tax @15% will be deducted from the bill and a TDS (tax deducted at source) certificate will be issued as per Income-tax rules. Suppliers should submit their offers along with the following information.

(a) period of validity, terms & conditions of the offer, (b) Approximate period of completion of the task and (c) copy of the registration and income-tax clearance certificate.

Additional Information:

Your sealed quotation (in your letter head) including all details, like taxes to be paid, transport charges etc., duly indicating our reference number mentioned above, due date & time of opening of quotations on the envelop, may be sent to "**Head, APPD, Engg. Hall No.4, Trombay, MUMBAI-400085**", on or before, **27th November 2017**. It is requested that the tender must be sent by Speed-post. The quotations received after the due date & by FAX/email will not be considered.

Yours faithfully,

R. K. Rajawat
Head, APPD, BARC

Copy to: A.P.O., GSS Section, Central Complex, BARC.

Annexure I

Electrical circuit as shown in Fig.1 is to be mounted on the highlighted section of the MS sheet shown in Fig. 2.

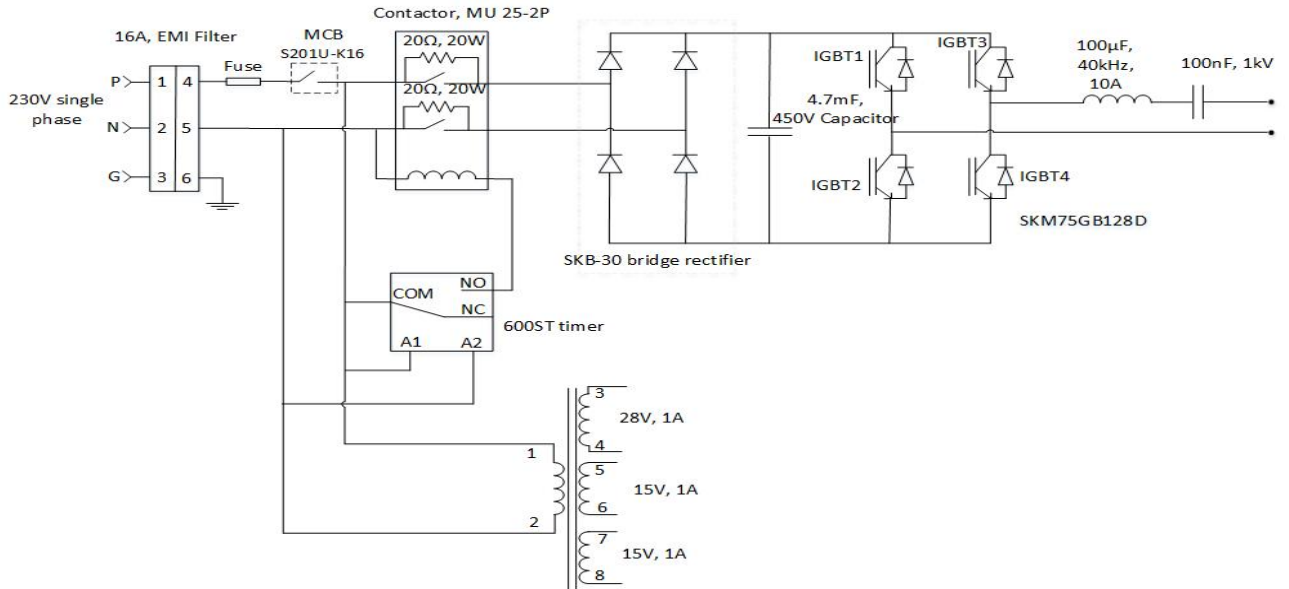

Fig. 1 Electrical circuit to be mounted on MS Sheet

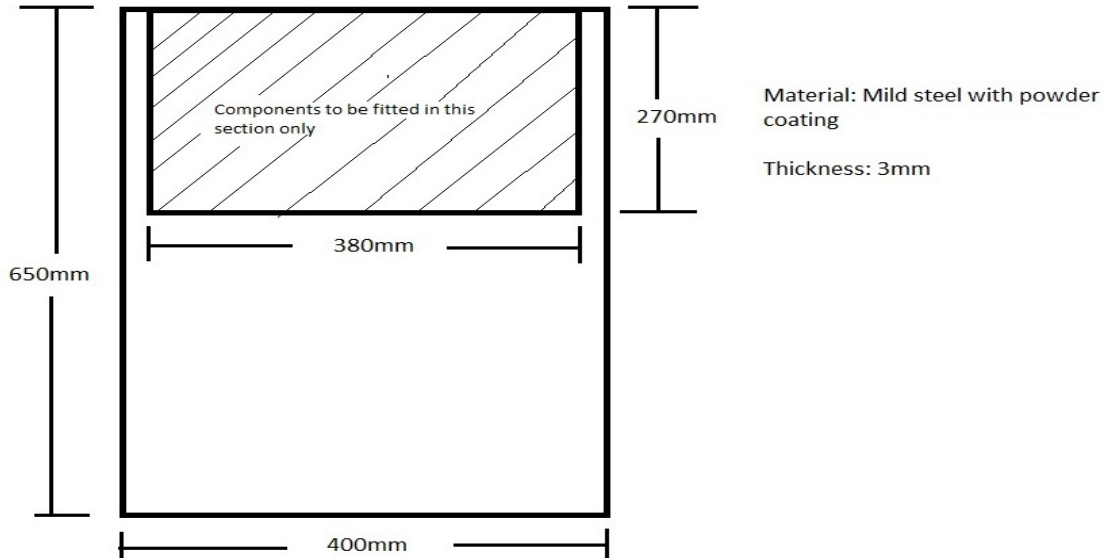

Fig. 2 Dimensions of MS sheet