

**Government of India  
Bhabha Atomic Research Centre  
Accelerator Control Division**

Ref: BARC/ACnD/17-18/515

Date: 03/08/2017

-----TO WHOM SO EVER IT MAY CONCERN-----

**Sub: Minor Fabrication job for "Fabrication of : 1. Copper Heat Spreader. ; 2. S.S. 304 HV Pad-lock." conforming to technical specification file no BARC/ACnD/17-18/515 dated 27/07/2017**

Dear Sir/Madam,

Quotations are invited for Fabrication of :

- 1 Copper Heat Spreader.
- 2 S.S. 304 HV Pad-lock.

conforming to technical specification as per file no BARC/ACnD/17-18/515 (Annexure – C-1,C-2,C-3)

1. Bidder shall quote for purchase of raw materials, fabrication, assembly, integration, testing and supply of all high vacuum components and its accessories.
2. Taxes and Excise Duties shall be quoted separately. Form AF / H whichever is applicable shall be provided, if required.
3. **The quotation must reach The Head, Accelerator Control Division by : 16/08/2017 (12:00 PM) and must be sent in a sealed envelope super scribed with the reference number & the due date given above only through India Ordinary Post/Speed Post.**
4. The address on the envelop should read:  
The Head,  
Accelerator Control Division,  
3-120S, 3rd Floor, Modlabs B-block, BARC,  
Trombay, Mumbai - 400 085.  
(Kind Attn: Shri N. R. Patel, SO/D, ACnD)
5. The bidder shall complete the job within 24 weeks from the date of firm work order issued to the bidder. The finished components shall be delivered by the bidder at Accelerator Control Division, BARC, Trombay, Mumbai - 400 085.
6. Head, Accelerator Control Division reserves the rights to accept / reject any or all quotations without assigning any reason.
7. Delivery charges if any must be clearly mentioned in the offer. Quotation must also indicate the validity of offer. Quotation must also indicate the VAT no and PAN no of the party.
8. Drawings / Sketches must be returned along with the offer.
9. The quotation has to be signed by authorized person with company seal.
10. Payment will be made by cheque only after satisfactory completion of work on production of bill, delivery challan and advance stamped receipt. It may be noted that IT @ 2% shall be deducted from your bills.
11. In case of technical clarifications, the suppliers may kindly contact Shri N. R. Patel, SO/D, ACnD (ExtNo: 022-25590435)

  
**P.V. Bhagwat**  
Head, IADD  
(Acting Head, ACnD)

## Annexure C-1

### Technical specifications : Copper Heat Spreader & S.S. 304 HV Pad-lock

- |   |             |
|---|-------------|
| 1. Copper Heat Spreader :                     | Qty: 8 Nos  |
| a) Material Copper                            |             |
| b) Dimensions are per drawing in Annexure-1-B |             |
| 2. S.S. 304 HV Pad-lock                       | Qty: 16 Nos |
| a) Material : Stainless Steel 304             |             |
| b) Dimensions are per drawing in Annexure-1-C |             |

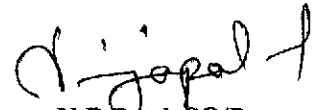
  
N.R. Patel, SO/D  
RFSS, ACnD

Copper Heat Spreader

Annexure-C-2

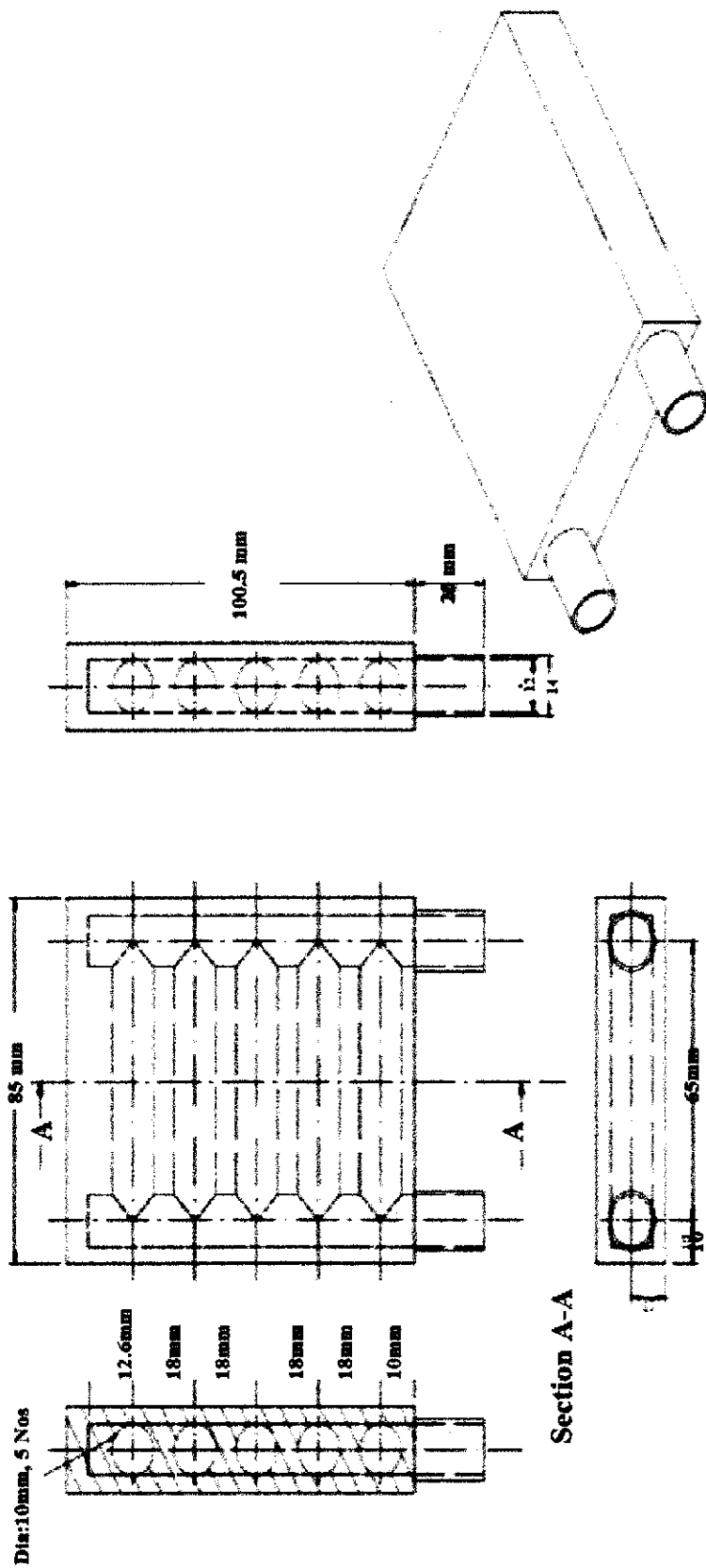

**Copper Heat Spreader**

All dimensions are in mm : Material : Copper

Annexure-C-3

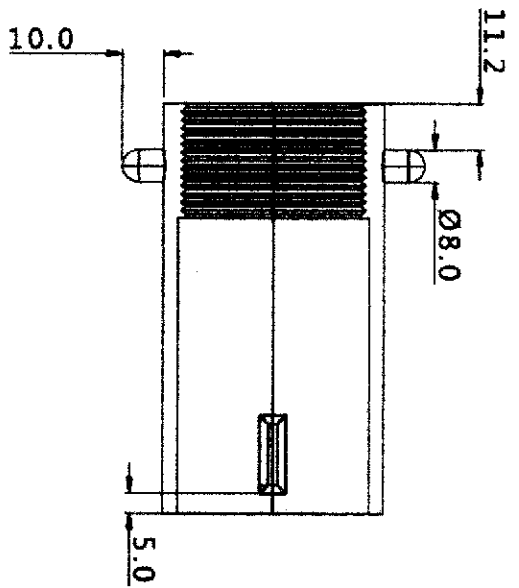
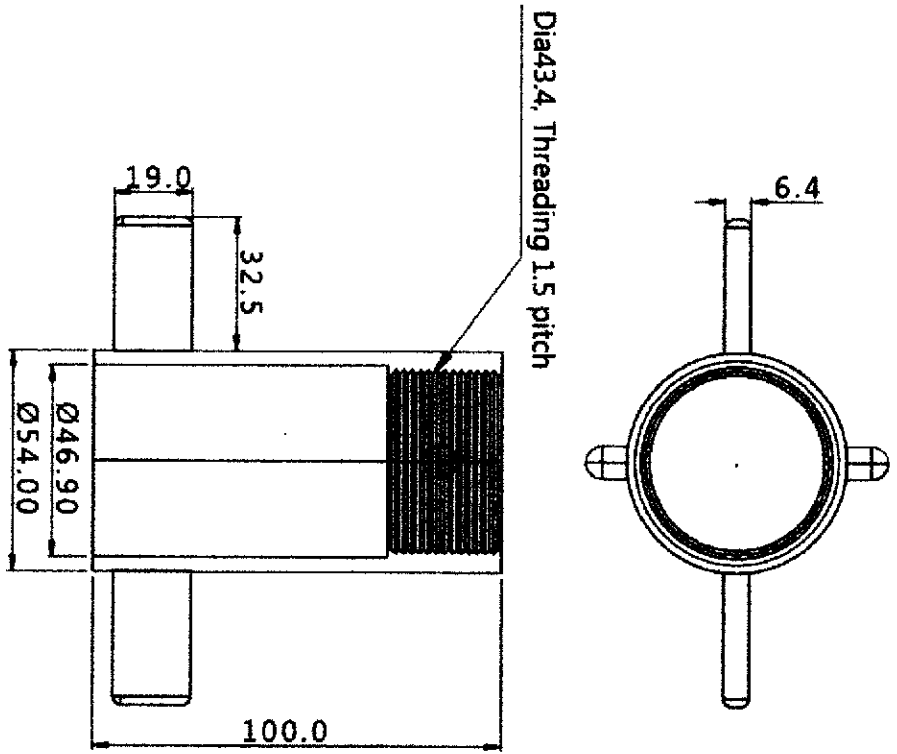

All dimensions are in mm : Material : SS 304