



सत्यमेव जयते

GOVERNMENT OF INDIA
DEPARTMENT OF ATOMIC ENERGY
BHABHA ATOMIC RESEARCH CENTRE
VISAKHAPATNAM



भारता परमाणु अनुसंधान केंद्र
BHABHA ATOMIC RESEARCH CENTRE

Computational Analysis Division

Ref: CAD/HEDM/WO/IND/22-23/31

Date: 28/02/2023

Subject: Notice inviting tender for;
“Fabrication and supply of long length Filament wound GFRP Barrels”
(See Annexure-I).

1. Quotations are invited for minor fabrication job as per details described below.
2. **Scope of work:** See details in Annexure-I.
3. **General guidelines for submitting tender**
 - You shall send your offer in a **sealed envelope** indicating delivery period, price inclusive of taxes and other relevant information by speed post to:

Head,
MPSS, Computational Analysis Division
Bhabha Atomic Research Centre
Village: Maduturu (Sub: P.O.)
Near Nagavaram Junction,
Gajuwaka-Yellamanchilli Highway
Atchutapuram, Visakhapatnam
Andhra Pradesh- 531011

(Kind Attention: Rahulnath P.P., SO/E,CAD, 0891-283-2149/ 8985875318)

- Quotation shall reach us on/or before **15/03/2023 by Speed Post/Courier/ Only.**
- On top left corner of the envelope please indicate
Quotation for– **“Fabrication and supply of long length Filament wound GFRP Barrels”** And
due date 15/03/2023
- Overwriting, scratching etc. must be avoided in the quotation. Rewriting the whole figure shall carry out any alteration in the figure. The authorized person from the firm shall countersign such figure.
- The delivery period mentioned in the quotation shall be strictly adhered to. If the contractor fails to supply and secure extension of delivery date before effecting delivery of the supply against the contract, acceptance of such item by the purchaser will in no way prejudice the right of the purchaser to levy liquidated damage nor will it be entitled to the contractor for payment of statutory levies that comes into force after the expiry of the delivery date.
- Minimum Guarantee/**Warranty period** of the material and workmanship shall be **One Year.**
- **Supplier shall mention clearly the PAN /TAN no. on quotation.**
- **GST number shall be clearly mentioned on Quotation.**
- All the charges and taxes shall be mentioned clearly.
- You may contact us for any clarification before **15/03/2023** (Shri. Rahulnath P.P., 0891-2832149,8985875318; rahulnath@barc.gov.in)

4. **Rates:**
As per Scope of Work.

5. Place of Delivery/Work:

Address: PEB-04,CAD, Bhabha Atomic Research Centre, Near Nagavaram Junction, Gajuwaka-Yellamanchilli Highway, Maduturu PO, Visakhapatnam, Andhra Pradesh- 531011.

5. PAYMENT TERMS:

1. Part payment/Advance or against delivery cannot be made.
2. Payment will be made only after satisfactory completion of work and on production of (along with Delivery Challan):
 - i. Bill/Invoice containing Location of supply, separate tax components along with PAN and GSTN numbers.
 - ii. Advance Stamped Receipt.
 - iii. Bank Account No, Bank and Branch name with IFSC code.
 - iv. Undertaking stating that GST has been promptly deposited with the authorities
3. It may be noted that:
 - i. Income tax @2% will be deducted from your bill.
 - ii. TDS (under GST) will be deducted as applicable from your bill of taxable goods and/or services, where the total value of such supply exceeds 2.50lakh.
 - iii. Declaration confirming filing of Income Tax Return from immediate two preceding years, in accordance with Section 206 AB of the Income Tax Act 1961, has to be submitted in the prescribed proforma along with necessary acknowledgements in support of declaration. In case the aforesaid declaration is not submitted, TDS/TCS shall be deducted at higher rates as instructed under the provisions of Income Tax Act.

6. CONFIDENTIALITY CLAUSE:

No, party shall disclose any information to any third party, concerning the matters under this contract generally. In particular, any information identified as "Proprietary" in nature by the disclosing party shall be kept strictly confidential by the receiving party and shall not be disclosed to any third party without the prior written consent of the original disclosing party.

This clause shall apply to the sub-contractors, consultants, advisers or the employees engaged by a party with equal force.

"Restricted information "categories under section 18 of the Atomic Energy Act,1962 and "Official Secrets" under section 5 of the official secrets act, 1923.

Any contravention of the above-mentioned provisions by any contractor, sub-contractor, consultant, adviser or the employees of a contractor will invite penal consequences under the aforesaid legislation.

Prohibition against use of BARC's name without permission for publicity purposes. The contractor or sub-contractor, consultant, adviser or the employees engaged by the contractor shall not use BARC's name for any publicity purpose through any public medial like press, radio, T.V. or Internet without the prior written approval of BARC.

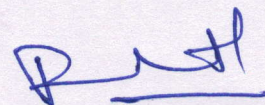

(Rahulnath P.P.)

SO/E, CAD

Phone: 0891-2832149,

Email: rahulnath@barc.gov.in

Scope of work
Fabrication and supply of long length Filament wound GFRP Barrels

The following item is to be fabricated and supplied;

Sl. No.	Item	Drawing No.	Quantity	Scope
02	GFRP Barrels	01	25Nos.	Fabrication & Supply

1. GFRP Barrels (Drg.No.01)

- a. Glass Fibre Reinforced Plastics (GFRP) barrels are to be made by **filament winding** technique.
- b. **CNC Machine** must be used for winding purpose.
- c. The same mandrel must be used for fabrication of GFRP barrels.
- d. Nominal Inner and outer diameter are 61.3mm and 65mm respectively.
- e. **60-65° winding angle** in forward and reverse directions has to be ensured.
- f. **600Tex ECR-Glass Fibre** has to be used for the purpose.
- g. Huntsman grade MY740 Araldite, HY918 Hardener and DY062 Accelerator is preferable mix of resin. If else those mixture satisfying the mixture properties may be used.
- h. Pre-stress of 1.5-2kgf has to be applied.
- i. Internal **surface finish** must be maintained within 0.005microns.
- j. Thickness has to be ensured within 2mm.
- k. Outer surface may be machined to the required dimension after making Barrel with larger thickness. The surface finish may be maintained within 0.05mm.
- l. **Straightness** must be ensured within 0.2mm/m. (Total 0.2mm in 2m)
- m. **Tolerance at starting end for inner diameter** must be ensured within +0.05mm.
- n. **Tolerance at finishing end for inner diameter** must be ensured within +0.40mm.

Note to the vendor

1. All conditions in the drawing and scope of work have to be **strictly adhered to**.
2. GFRP barrel manufacturing must not start before getting approval from Indentor/Engineer-In-Charge (EIC) regarding the quality of mandrel.
3. **Necessary measuring tools** must be available at vendor's site for measuring straightness, surface finish, and tolerances.
4. GFRP barrel dimension must be strictly adhered to.
5. **Material property of Fibre and Araldite** used must be shared with Indentor.
6. **Curing process for Fibre/Epoxy** must be followed as per standards.
7. Delivery should be made only after getting approval from EIC.
8. **No part payment** will be done for any work undertaken. Payment will be made only after successful completion of work and approval from Engineer-In-Charge.
9. The vendors are encouraged to hold **prior discussion with EIC** for any clarifications.

GENERAL REQUIREMENTS:

- a) The vendors are encouraged to hold prior discussions with the indenter for any clarifications.
- b) Finished products should be delivered to the address given below.

Address:

“Stores Officer, Bhabha Atomic Research Center, Near Nagavaram Junction, Nagavaram-
Atchutapuram Highway, Visakhapatnam, Andhra Pradesh- 531011”

- c) The cost of transportation/delivery if any should be mentioned in the quotation.
- d) Single order will be placed for all the above items and no partial work is permitted.
- e) Minimum Guarantee/**Warranty period** of the raw material and workmanship shall be **One Year**.
- f) **Contact Persons:**

a) **Shri. Rahulnath P.P.**, Computational Analysis Division, BARC

Contact details: rahulnath@barc.gov.in

Phone: 0891-283-2149, 8985875318

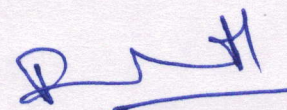

(Rahulnath P.P.)
SO/E, CAD

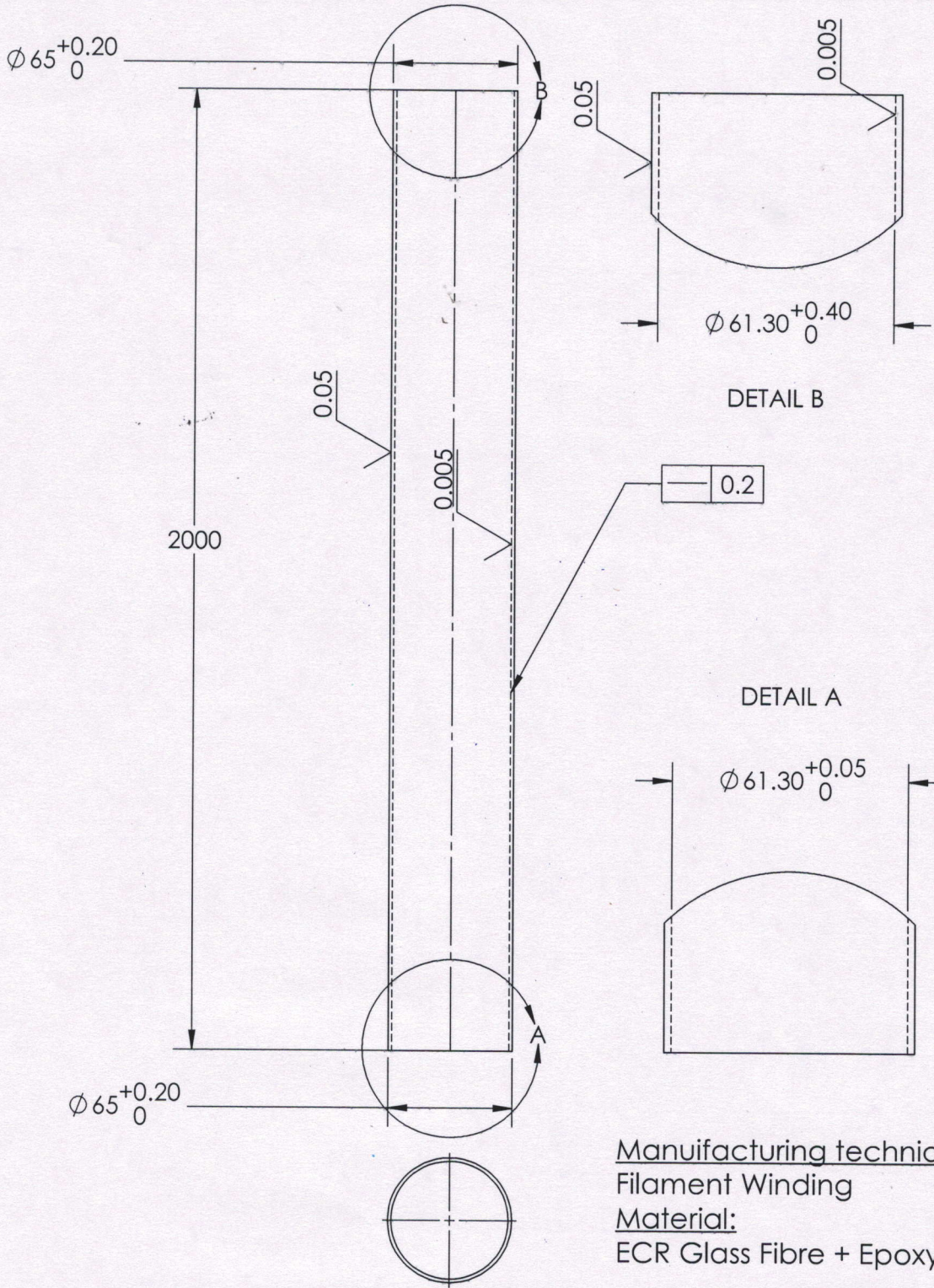

Manufacturing technique:
 Filament Winding
Material:
 ECR Glass Fibre + Epoxy

GFRP Barrel		
DRG. No.:01	All dimensions are in mm	
Quantity:25	SCALE:1:4	Material:GFRP
DATE:20/02/2023	MF:22-23/31	NAME & Sign.:Rahulnath

