



GOVERNMENT OF INDIA
DEPARTMENT OF ATOMIC ENERGY
BHABHA ATOMIC RESEARCH CENTRE
VISAKHAPATNAM



Computational Analysis Division

Ref: CAD/HEDM/WO/IND/22-23/28

Date: 15/02/2023

Subject: Notice inviting tender for;
“Machining and supply of Delrin C-Blocks”
(See Annexure-I)

1. Quotations are invited for minor fabrication job as per details described below.
2. **Scope of work:** See details in Annexure-I.
3. **General guidelines for submitting tender**
 - You shall send your offer in a **sealed envelope** indicating delivery period, price inclusive of taxes and other relevant information by speed post to:
Head,
CAD, Computational Analysis Division
Bhabha Atomic Research Centre
Village: Maduturu (Sub: P.O.)
Near Nagavaram Junction,
Gajuwaka-Yellamanchilli Highway
Atchutapuram, Visakhapatnam
Andhra Pradesh- 531011
(Kind Attention: Rahulnath P.P., SO/E, CAD, 0891-283-2149/ 8985875318)
 - Quotation shall reach us on/or before **01/03/2023 by Speed Post/Courier/ Only.**
 - On top left corner of the envelope please indicate
Quotation for– **“Machining and supply of Delrin C-Blocks”** And due date 01/03/2023
 - Overwriting, scratching etc. must be avoided in the quotation. Rewriting the whole figure shall carry out any alteration in the figure. The authorized person from the firm shall countersign such figure.
 - The delivery period mentioned in the quotation shall be strictly adhered to. If the contractor fails to supply and secure extension of delivery date before effecting delivery of the supply against the contract, acceptance of such item by the purchaser will in no way prejudice the right of the purchaser to levy liquidated damage nor will it be entitled to the contractor for payment of statutory levies that comes into force after the expiry of the delivery date.
 - Minimum Guarantee/Warranty period of the material and workmanship shall be **One Year.**
 - **Supplier shall mention clearly the PAN /TAN no. on quotation.**
 - **GST number shall be clearly mentioned on Quotation.**
 - All the charges and taxes shall be mentioned clearly.
 - You may contact us for any clarification before **01/03/2023** (Shri. Rahulnath P.P., 0891-2832149,8985875318, rahulnath@barc.gov.in)
4. **Rates:**
As per Scope of Work.

5. Place of Delivery/Work:

Address: Stores Officer, Bhabha Atomic Research Centre, Near Nagavaram Junction, Gajuwaka-Yellamanchilli Highway, Maduturu PO, Visakhapatnam, Andhra Pradesh- 531011.

5. PAYMENT TERMS:

- a. Part payment/Advance or against delivery cannot be made.
- b. Payment will be made only after satisfactory completion of work and on production of (along with Delivery Challan):
 - i. Bill/Invoice containing Location of supply, separate tax components along with PAN and GSTN numbers.
 - ii. Advance Stamped Receipt.
 - iii. Bank Account No, Bank and Branch name with IFSC code.
 - iv. Undertaking stating that GST has been promptly deposited with the authorities
- c. It may be noted that:
 - i. Income tax @2% will be deducted from your bill.
 - ii. TDS (under GST) will be deducted as applicable from your bill of taxable goods and/or services, where the total value of such supply exceeds 2.50lakh.
 - iii. Declaration confirming filing of Income Tax Return from immediate two preceding years, in accordance with Section 206 AB of the Income Tax Act 1961, has to be submitted in the prescribed proforma along with necessary acknowledgements in support of declaration. In case the aforesaid declaration is not submitted, TDS/TCS shall be deducted at higher rates as instructed under the provisions of Income Tax Act.

6. CONFIDENTIALITY CLAUSE:

No, party shall disclose any information to any third party, concerning the matters under this contract generally. In particular, any information identified as "Proprietary" in nature by the disclosing party shall be kept strictly confidential by the receiving party and shall not be disclosed to any third party without the prior written consent of the original disclosing party.

This clause shall apply to the sub-contractors, consultants, advisers or the employees engaged by a party with equal force.

"Restricted information "categories under section 18 of the Atomic Energy Act,1962 and "Official Secrets" under section 5 of the official secrets act, 1923.

Any contravention of the above-mentioned provisions by any contractor, sub-contractor, consultant, adviser or the employees of a contractor will invite penal consequences under the aforesaid legislation.

Prohibition against use of BARC's name without permission for publicity purposes. The contractor or sub-contractor, consultant, adviser or the employees engaged by the contractor shall not use BARC's name for any publicity purpose through any public medial like press, radio, T.V. or Internet without the prior written approval of BARC.

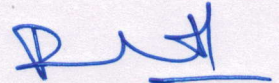

(Rahulnath P.P.)
SO/E, CAD

Phone: 0891-2832149,

Email: rahulnath@barc.gov.in

Scope of work

Machining and supply of Delrin C-Blocks

Item to be fabricated/supplied;

Sl. No.	Coil type	Dimension	Quantity
01	Delrin C-Block_Open	Length:140mm Height:60mm Width:80mm C-Radius:R35mm Ends: Open	24Nos.
02	Delrin C-Block_Closed	Length:140mm Height:60mm Width:92mm C-Radius:R35mm Ends: Closed	16Nos.
03	M10 SS Bolt	Length-150mm	100Nos.

01. Delrin C-Block_Open(Drg.No.1)

- a. All operation has to be made in **CNC machine only**.
- b. Material: Delrin
- c. Overall dimension: 140x80x59mm
- d. C- cut of R35 has to be made on the surface 140x59mm as mentioned in the drawing.
- e. The Origin of R35 must be at a height of 60mm from base (140x80mm).
- f. Open holes of 10.2mm have to be made on 140x80mm surface as shown in drg.no.1.
- g. The holes are to be made 40mm part. And each row 110mm apart.
- h. Tolerance has to be maintained as mentioned in drawing.

02. Delrin C-Block_Closed

- a. All operation has to be made in **CNC machine only**.
- b. Material: Delrin
- c. Overall dimension: 140x92x59mm
- d. C- cut of R35 has to be made on the surface 140x59mm as mentioned in the drawing.
- e. The Origin of R35 must be at a height of 60mm from base (140x92mm).
- f. Open holes of 10.2mm have to be made on 140x92mm surface as shown in drg.no.2.
- g. The holes are to be made 40mm part. And each row 110mm apart.
- h. Tolerance has to be maintained as mentioned in drawing.

03. SS Bolt

- a. SS Bolt Size M10
- b. Bolt length-150mm

Note to the vendor

- a. All operations are to be done in CNC only.
- b. All machined components must adhere to dimension as mentioned in the drawing.
- c. The vendors are encouraged to hold prior discussions with the indenter for any clarifications.
- d. The cost of transportation/delivery if any should be mentioned in the quotation.
- e. It is mandatory to mention prices of each item separately.
- f. Single order will be placed for all the above items and no partial work is permitted.
- g. Minimum Guarantee/Warranty period of the raw material and workmanship shall be One Year.
- h. **Contact Persons:**

a) **Shri. Rahulnath P.P.**, Computational Analysis Division, BARC

Contact details: rahulnath@barc.gov.in

Phone: 0891-283-2149, 8985875318

(Rahulnath P.P.)
SO/E, CAD

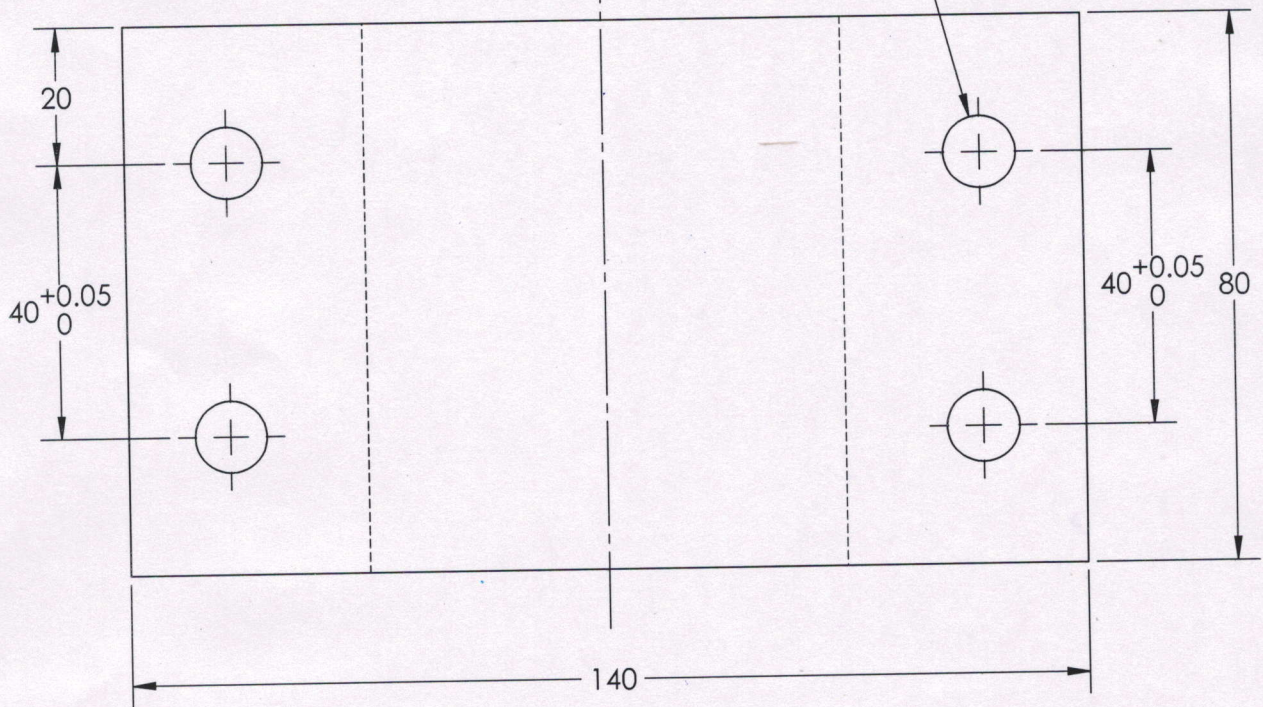
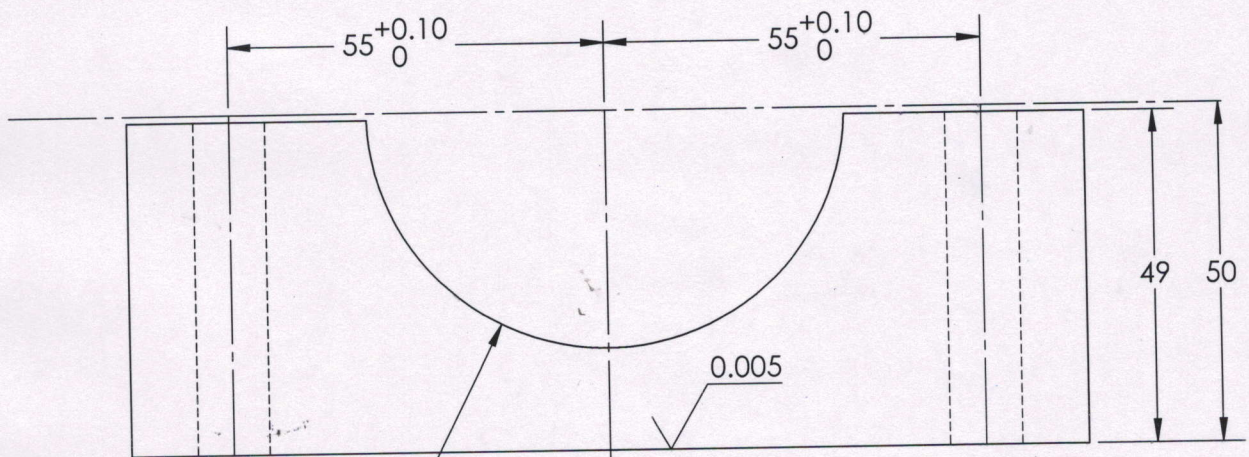

Delrin C-Blocks_Open

DRG. No.:01

All dimensions are in mm

Quantity:24Nos.

SCALE:1:1

Material:Delrin

DATE:15/02/2023

MF:22-23/27

NAME & Sign.:Rahulnath

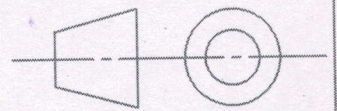

Rahulnath

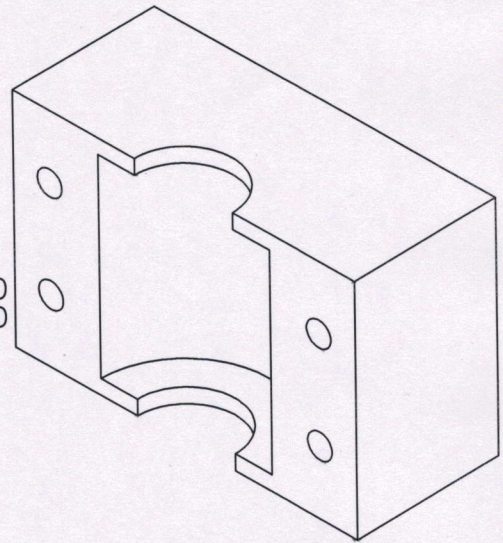
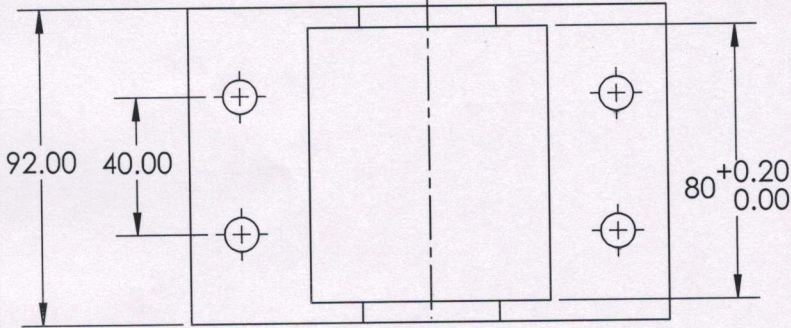
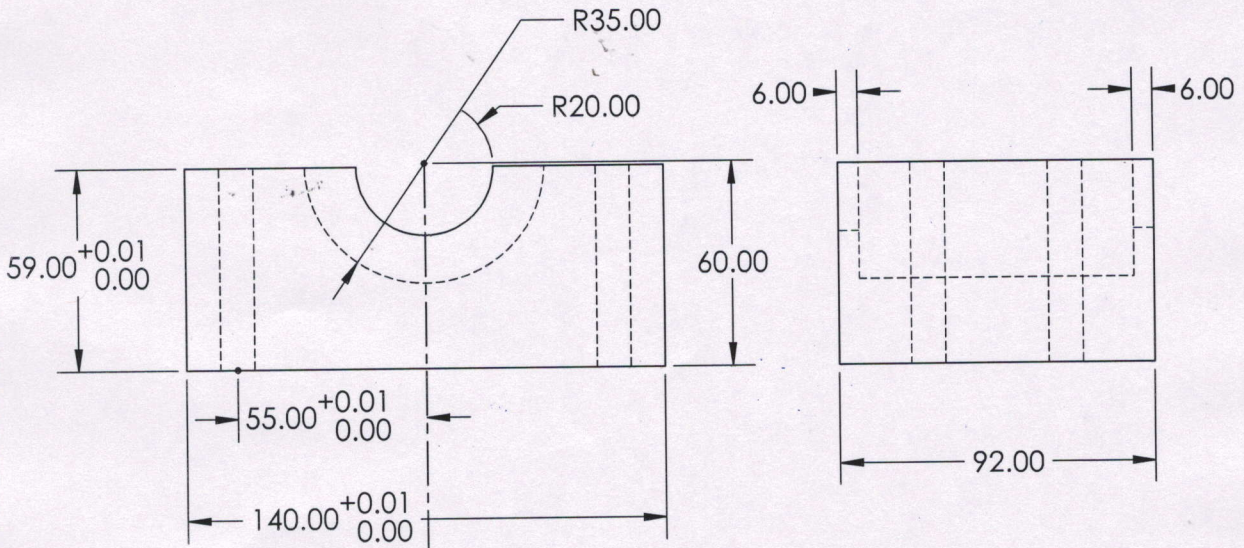

Delrin_C-Block_Closed

DRG.NO.:02	All Dimensions are in mm		
Quantity:16	Scale :	Material:Delrin	
Date:15/02/2023	MF:22-23/28	Name&Sign : Rahulnath	