



BARC

NEWSLETTER

No. 240
January
2004



DEVELOPMENT AND EVALUATION PROGRAM ON MULTICHANNEL ACOUSTIC EMISSION ANALYSER

G. P. Srivastava*, S. Bhattacharya, H. R. Mehta,
V. S. Mageshkumar, K. G. Menon, R. C. Deshpande, A. K. Singh
and A. K. Sharma

Control Instrumentation Division

Introduction

Acoustic Emissions (AE) are stress waves produced by sudden movement in stressed materials. The classic sources of AE are defect-related deformation processes such as crack growth and plastic deformation. The source of the AE energy is the elastic stress field in the material. Without stress, there is no emission. Therefore, an AE inspection is usually carried out during a controlled loading of the structure. It is cost effective, safe and attractive because it is less geometry sensitive, less intrusive on plant/processes, requires access only at sensors and tests whole structure at once. Using various AE test methodologies based on Kaiser effect and Felicity Ratio, structures under test can be classified. AE applications range from laboratory to production quality control to structural testing.

Acoustic Emission signal is particularly wide band in nature, but engineering applications limit the range for practical purposes to 100KHz-1MHz. It is always buried in noise. This necessitates AE instrumentation to have intelligent hardware and software capable of real time high-speed data processing, analysis and filtering of noise. Keeping this in mind, a PC-based Four Channel Acoustic Emission Analyser (AEA) has been developed with on-board FPGAs for Real Time AE Parameter

*Presently CMD of ECIL

Contents

1. Development and evaluation program on multichannel acoustic emission analyser1
2. Calcium iodate - another effective blocker of radio-iodine uptake by the thyroid gland 11
3. Farmers' rallies on Trombay groundnut varieties15
4. Incell automated glass vial sealing system for radiopharmaceutical products16
5. Training school graduation function17
6. "परमाणु ऊर्जा विभाग-स्वर्ण जयंती वर्ष" के उपलक्ष्य में सांस्कृतिक कार्यक्रम का आयोजन18
7. DAE and CERN - a collaboration 18
8. Awareness programme in 'Radiological and industrial safety' 19
9. Fire Service Week - 200319
10. National workshop on radiochemistry and applications of radioisotopes21
11. Training course in basic radiation protection23
12. भा.प.अ. केंद्र के वैज्ञानिकों को सम्मान / BARC scientists honoured 24

Extraction, Waveform Capture, Storage and Analysis of AE signals with Windows-98 based Graphical User Interface (GUI). This system also has capability to locate AE sources using location algorithms. It has been continually used for validation and acceptance in various in-house applications like seal plug leak detection of PHWRs and crack growth studies on PHT piping components. Sixteen Channel AE System is being developed based on Compact PCI platform with master and slave modules. This system will find applications in proof testing of large pressure vessels and bottom inspection of storage tanks in various industries.

AEA: System Overview

Any typical AE Instrumentation (Fig.1) consists of Piezoelectric Sensor (Resonant and Wideband) for signal detection, Preamplifier (Voltage and Charge type) for signal amplification and Multichannel Data Acquisition, Processing and Analysis Unit.

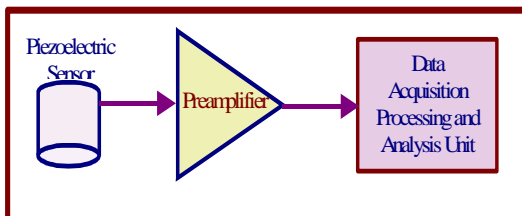

Fig. 1 Typical block diagram of AE instrumentation

Four Channel Acoustic Emission Analyser

It is based around an Industrial Personal Computer (Fig. 2) and consists of Real Time AE Parameter Extractor (RTAEPE) and Transient Analyser (TA) Cards (Fig. 3a and 3b).

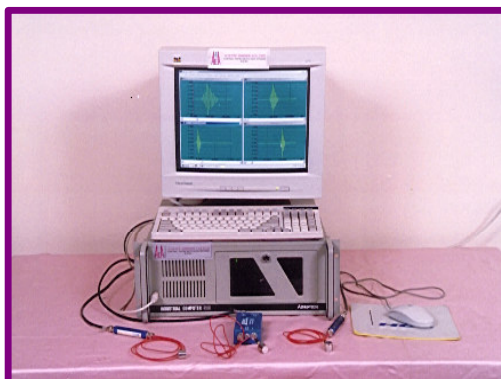

Fig. 2 Four Channel Acoustic Emission Analyser



Fig. 3a Real Time AE Parameter Extractor Card

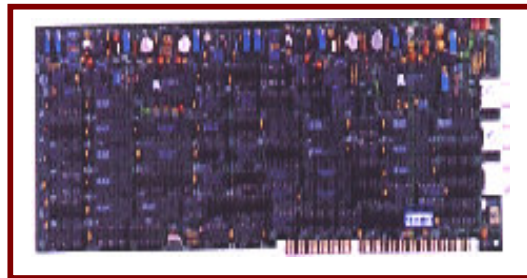

Fig. 3b Transient Analyser Card

The architecture of the system is shown in Fig. 4. The RTAEPE and TA cards are configured as ISA bus compatible PC Add-on Cards.

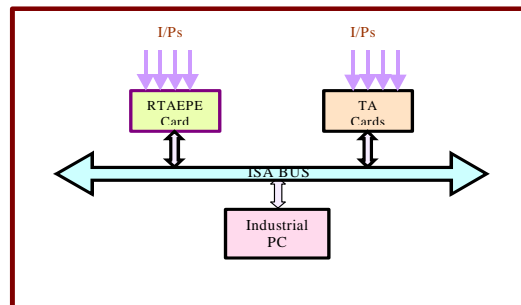

Fig. 4 Architecture of Four Channel AE Analyser

The system has capability of Real Time AE Parameter Extraction, Transient AE Waveform Analysis and AE Source Location. The biggest advantage of the system is that it is portable and can be customized for specific applications. The system has been calibrated, evaluated and standardized for all possible setups of AE techniques for its intended applications.

Real Time AE Parameter Extraction

Hardware:

- Four Channels in each Card
- 14-bit resolution on hit data with sampling frequency of 10 MHz.

- Signal Bandwidth 1 MHz
- Acquisition Speed to disc > 8000 Hits/sec.
- Inbuilt intelligence with HDT, HLT, PDT settings.

The signal flow in card is depicted in Fig 5. The Programmable Gain Amplifier (PGA) boosts the input signal with a gain selection of 0, 20, 40 or 60 dB. The output of the PGA is digitized by using 14-bit ADC. This 14-bit digital data stream

is then used by FPGAs to extract all important parameters of AE at real time. By optimum setting of combination of HDT, HLT and PDT, user can set the system to capture AE Hits at maximum speed at the same time rejecting unwanted reflections for particular applications. PC reads all AE parametric data through ISA bus. During experiments, other parameters such as load etc. can also be recorded as parametric inputs.

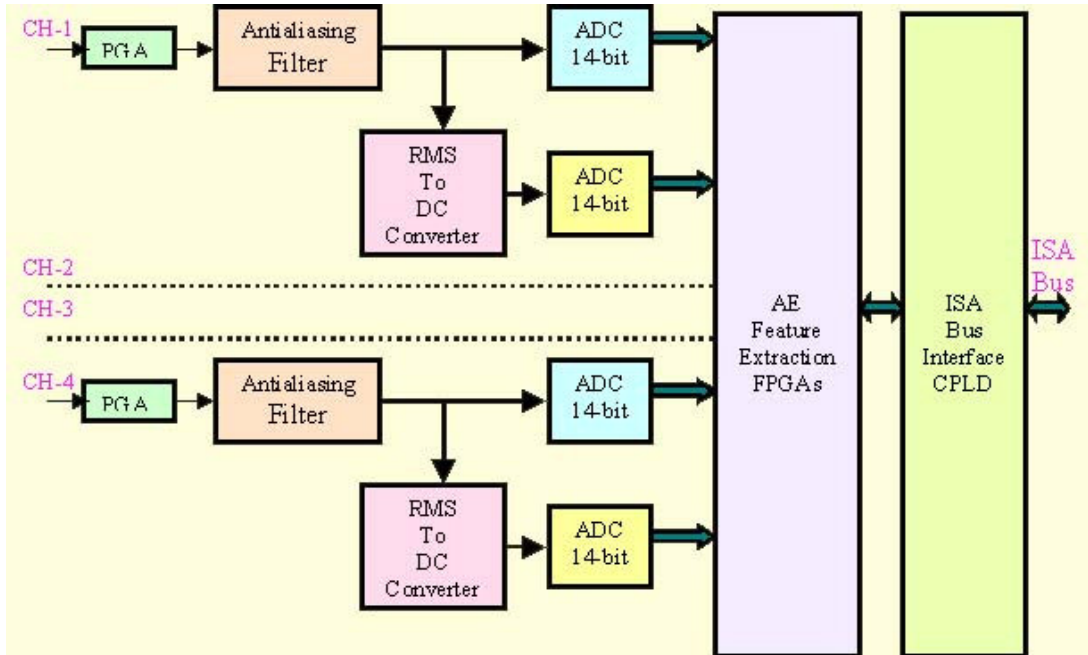

Fig. 5 Block diagram of Real Time AE Parameter Extractor Card

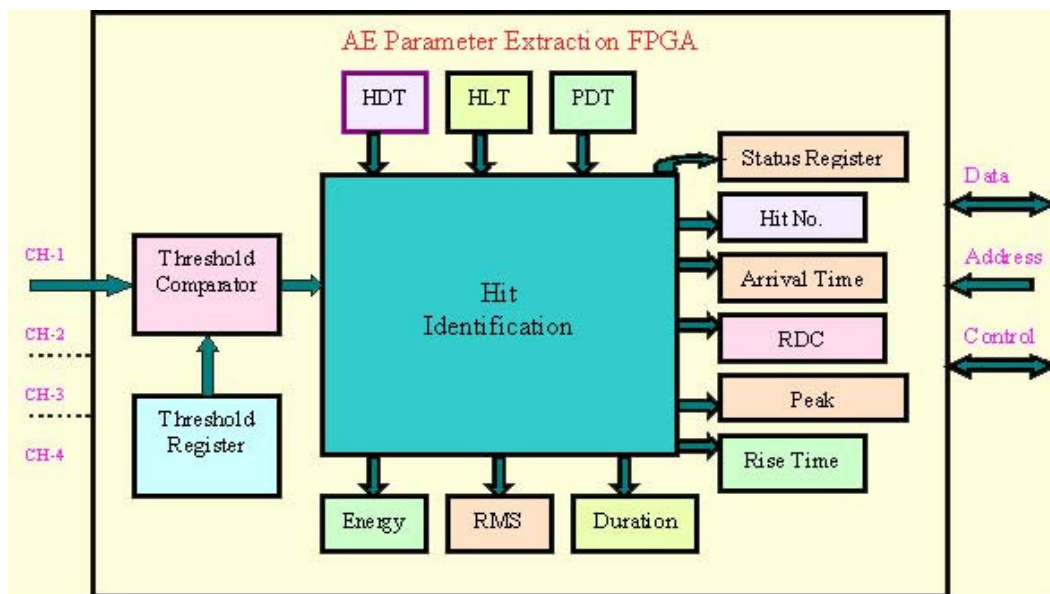

Fig. 6 Block diagram of AE Parameter Extraction FPGAs

AE Feature Extraction FPGA

Two FPGAs are used onboard to extract all important AE Parameters from all the four channels independently. These FPGAs take 14-bit data streams from four channels as input, which is then compared with threshold to identify the AE Hits with the help of inbuilt intelligence of HDT, HLT and PDT. All the AE parameters extracted are then stored in different registers. PC communicates with FPGAs with status registers and interrupts. Two Xilinx SPARTAN IIE FPGA devices (XC2S50E) with 50 K gates are used for this purpose. FPGA development and implementation tools from Xilinx (ISE 5.1) and Simulation tools from Modelsim were used for this development.

Software:

- 32-bit Windows-98 based software.
- System Input Gain, Threshold, HDT, HLT, PDT setting.
- Multiple window, multiple graph plotting.

- Types of plots: Cumulative, Distribution, Point and Rate plots
- Linear and Planer source location.
- Offline Parametric Filtering

Software is hit-driven and it records all the important AE parameters for each hit from the AE signal. It comprises of various modules (Fig. 7) for Hardware Configuration, Online Data Capture, Display and Storage, Off Line Graphical Display and Parametric Filtering and, Standard File Operations Module.

The parameters that are captured include the Ring Down Counts, Cumulative Ring Down Count, Peak Amplitude, Rise Time, Event Duration, Energy and RMS. The AE parameter data can be plotted and analyzed offline to get information for correlation with other physical parametric inputs.

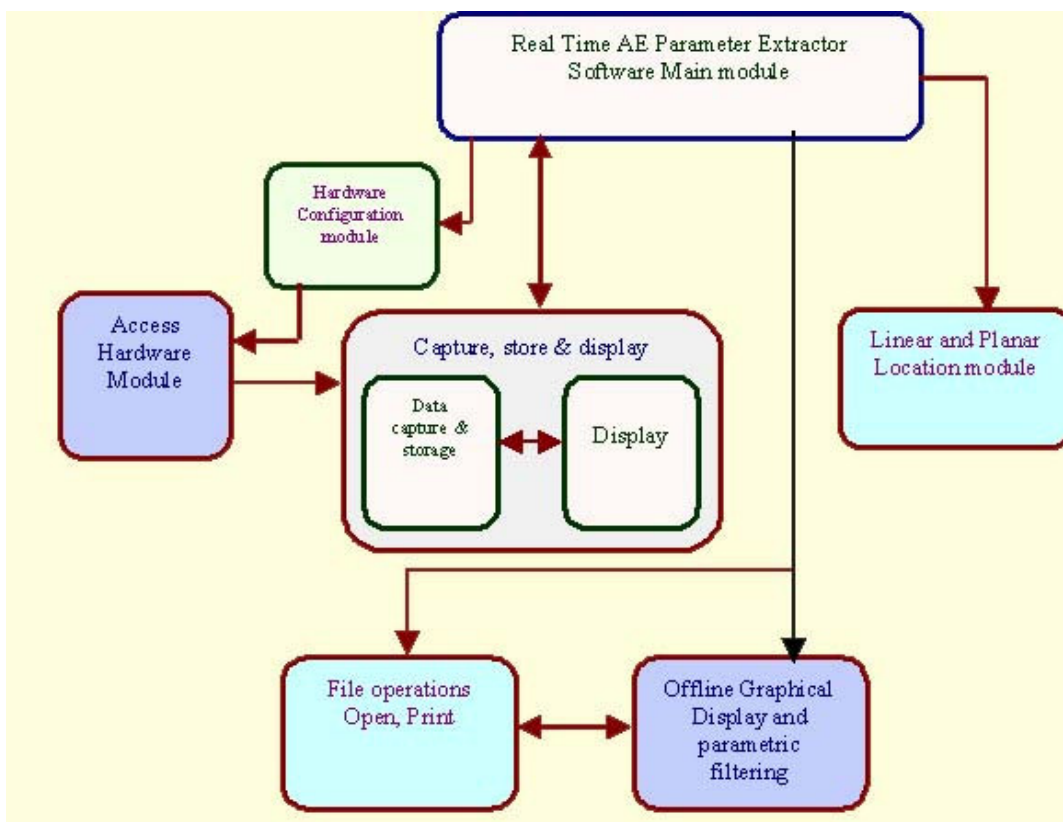

Fig. 7 Software flow diagram for Real Time AE Parameter Extraction

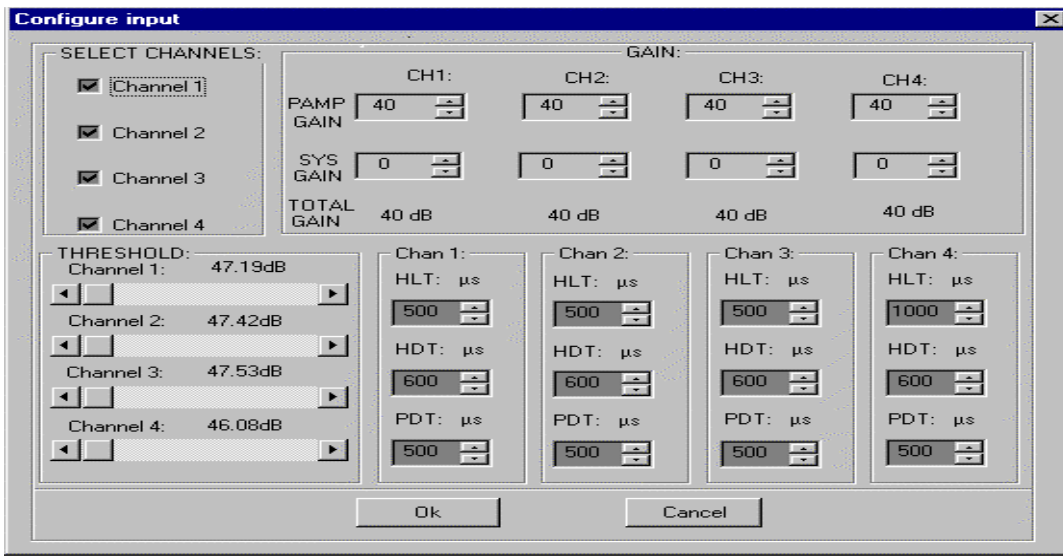

Fig. 8 Snapshot of Channel setting menu

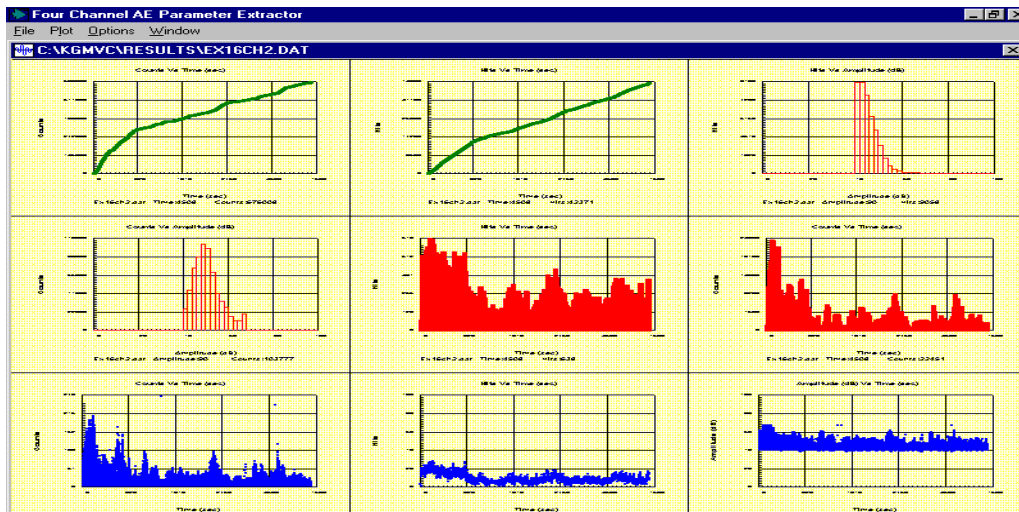

Fig. 9 Multiple plots of AE parameters

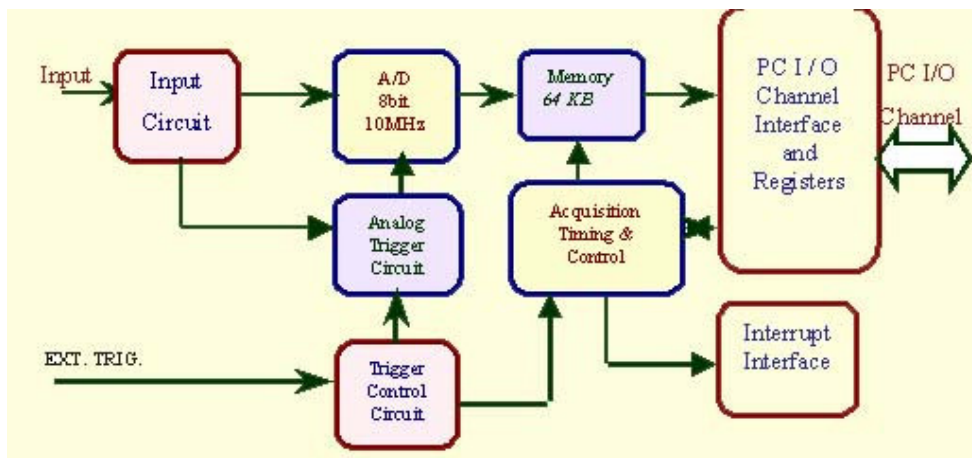

Fig. 10 Block diagram of Transient AE Waveform Analyser Card

Transient AE Waveform Analysis

Hardware:

- Inputs: Four ± 1 Volt bipolar or 0 to -2 volt Unipolar analog single ended Channels
- Sampling Rate: Programmable from 10 MSPS to 350 SPS
- On board memory: 2 x 64 Kbytes
- Data transfers: Programmed I/O or Interrupt
- A/D Conversion: Flash ADC
- Resolution: 8 bits
- Trigger Conditions: Level, Edge, Bi-Trigger, Hysteresis and External.

Here the system has the capability to achieve high-speed sampling, digitization and storage of analog AE waveforms from four independent input channels. The signal flow in card is depicted in Fig. 10.

The input circuit is an emitter follower circuit, which gives high input impedance. The A/D unit converts the analog input signal into digital 8-bit samples having a programmable sampling rate from 10MSPS to 300SPS, depending on the various trigger conditions set by the analog trigger circuit and the trigger control circuit. On occurrence of a trigger the digital data is stored in

onboard memory of 64kB per channel. Timing and Control Unit controls the timing of acquisition.

Software:

- 32-bit Windows-98 based user friendly software.
- User defined simultaneous AE waveform capture, display and storage.
- Single shoot and Continuous mode operation.
- Software settings for Channel selection, Sampling Rate, Trigger mode, Record length, Pre-trigger and Post-trigger data.
- Offline analysis in time (AE Parameter extraction) and frequency domain (FFT, FIR filtering).

The software is capable of detailed waveform acquisition of AE bursts, their storage and replay and for post analysis of the data in time and frequency domains. It consists of a main module and subsidiary modules (Fig. 11) for Hardware Initialization, Data Capture, Frequency Analysis, Filter and Envelope Detection, Graphical Display and File Operations.

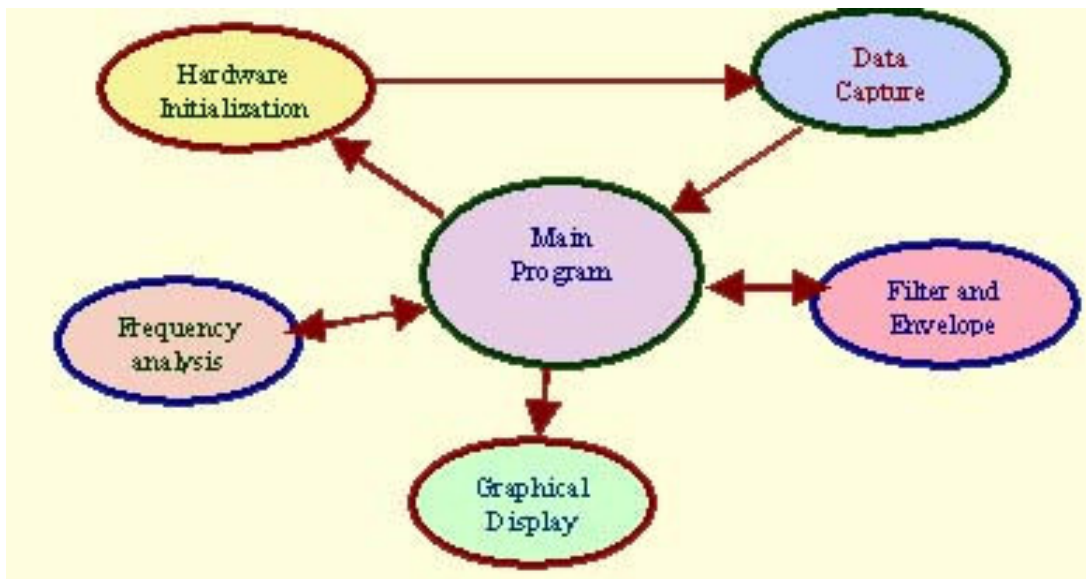

Fig. 11 Software modules for Transient Analyser software

AE Source Location

Detecting flaws at an early stage is one of the merits of using Acoustic Emission technique. The most important application of AE is flaw location in real-time. This requires a multi-channel AE system. Various algorithms are used to locate defects in structures of different shapes and dimensions such as pressure vessels and storage tank bottoms. These algorithms use the arrival times of AE Hits. One of the popular algorithms used is the method of triangulation. In this method, differences in arrival times of the propagating pulse at each of the sensors are used. These arrival times, along with knowledge of appropriate velocity of sound in the vessel, permits the location of an incrementing flaw. The accuracy with which the flaw can be detected depends upon the sound velocity and the accuracy of the arrival time measurement. Minimum of two sensors are required for location of flaws along straight line, while for planar location at least three sensors are required. The inputs to the system consist of the positions of the sensors, the differences in the arrival times of the signals between the first hit sensor and the rest of the sensors and the velocity of the wave through the material. The

location of AE source is then given in terms of x-y co-ordinates in the X-Y plane.

Locating sources on huge structures requires more number of sensors and the computation time increases likewise. So algorithms were developed to locate source with improved speed and better resolution of source zone. The source location computation algorithm uses vector geometry to compute the source location, instead of trigonometric geometry, so that faster matrix operations can be applied to reduce computation time. The algorithm requires one more sensor as compared to the triangulation method but compensates this by giving speed gain by a factor of 11(approx.). The algorithm is based on the fact that if we know four points on four concentric circles, and know the difference of the radii of the circles, we can compute the common centre (source). To reduce errors, the convergence algorithm was developed which exploits the property of pentagon, that on joining the vertices of the pentagon we get another pentagon, with shape resembling the original pentagon. Thus we converge the source zone, while we maintain the basic geometry unchanged.

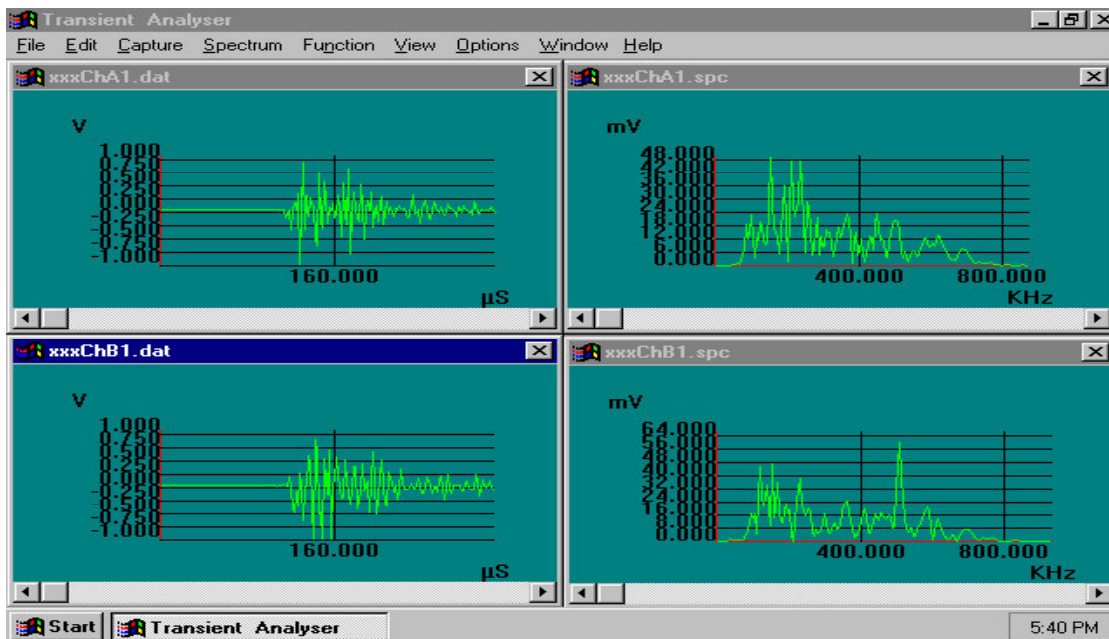

Fig. 12 Snapshot of AE signals and their FFTs

Sixteen Channel AE System

AE-Sensor and Preamplifiers

A consolidated program for development of AE-sensor has been initiated. This was needed as availability of required sensors is mostly under constraint and AE sensors are also under continuous phase of development. Thus for a unrestrained supply of AE- sensors and customization of sensors for typical reactor based applications, efforts are under way for indigenous development of multiple type of AE-sensors. Efforts for development of PZT material with help of institutes like NPL are underway. Electro-mechanical parameters optimization for sensors to be used for different applications are being explored in depth. AE-Sensor material, shapes, sizes and housing is being investigated in detail. Dynamic finite element method modeling for drawing inferences to optimal PZT parameters after studying interaction of AE-waves with AE sensor model with housings has

been undertaken. Electrical parametric simulation studies are also planned for developing these sensors. High temperature and high radiation sensors are also under development along with customized wave guides. Testing and calibration of these sensors with facilities in the lab are underway. Both voltage and charge type preamplifiers are being developed with suitable filtering units.

Acoustic Emission Data Analysis and Processing Unit

An advanced Sixteen Channel AE Analyser is under development whose block diagram is shown in Fig 13. This system consists of a Compact PCI backplane, Acoustic Emission Data Analysis Cards (AEDAQ) comprising of an analog measurement and digital signal processing section for Four Channels and a powerful CPU card with a complete set of peripherals.

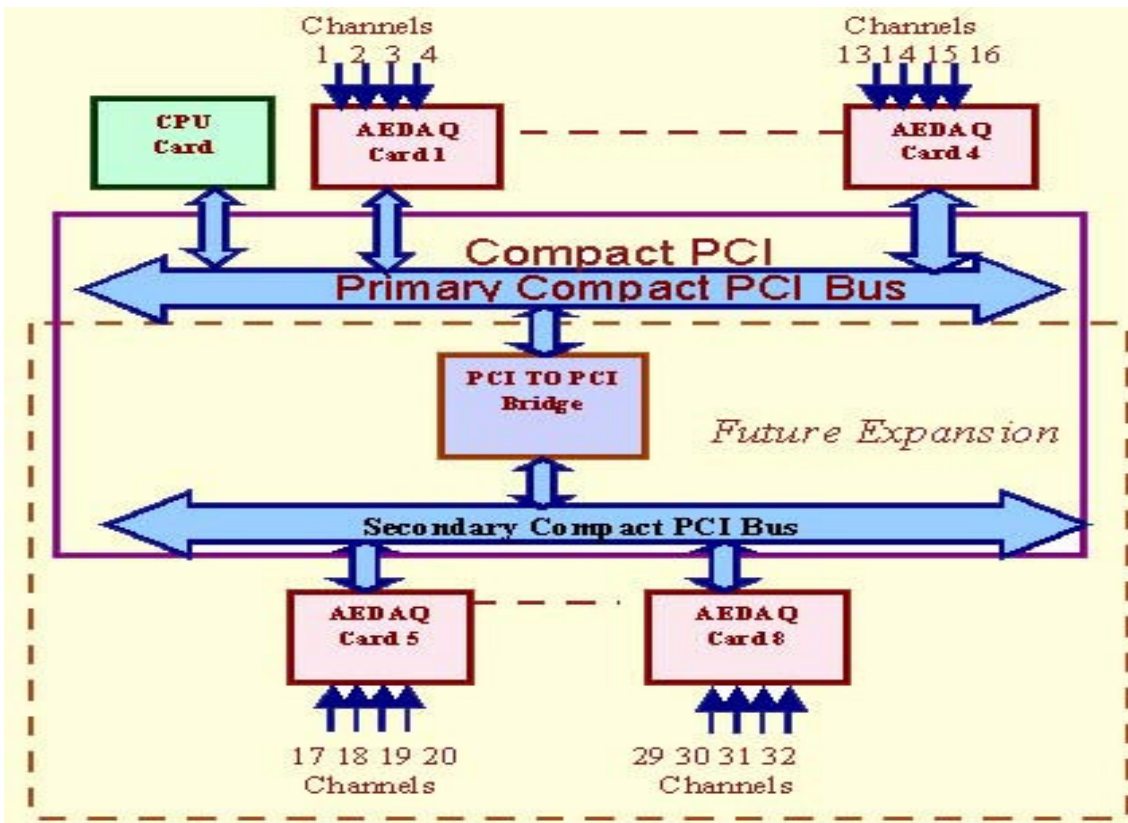

Fig. 13 Block diagram of 16-channel AE System

The analog measurement chain of each channel consists of an AE sensor, a preamplifier and an AEDAQ Card located in CompactPCI backplane. The AEDAQ card uses Digital Signal Processor (DSP) and Field Programmable Gate Array (FPGA) for feature extraction and waveform analysis.

DSP transfers the AE-feature data as well as parametric data via PCI bus to the CPU card, where all data is assembled into data sets. All data sets are temporarily stored in the memory of CPU card and then transferred to an AE-file on the hard disk under the control of acquisition program. In parallel to the transfer of the AE data, the DSP can read the waveform data from AEDAQ card transient recorder memory and then transfer to the transient data file on the CPU card hard disk.

Frequency and time domain analysis can be performed on the waveform data and analysed in combination with the traditional AE data. During data acquisition, or later, after the test, the data can be and displayed in various different plots on the screen. The software is being developed

using VC++ under Windows 2000/XP platform with rich GUI.

DAE Applications

Sorting of D₂O leakage from seal plugs in coolant channels (PHWRs)

In-service inspection of seal plugs in coolant channels of Pressurised Heavy Water Reactors (PHWRs) during operation is an important Non-Destructive Technique (NDT).

Seal-plug condition well judged assures a long reactor operation time at a stretch as far as seal-plug leakage is concerned this is significant as it is boundary protection to PHT system and thus limiting tritium content in vault areas as well.

System was calibrated on fuelling machine test facility at Hall-7, where it could detect a leak as small as 80 gm/hour. This technique was further developed by performing experiments at KAPS-2. The system was put to actual use at NAPS-2 where it detected leaks from 3 to 4 Channels out of 306 channels scanned. This application was developed jointly by RTD, LPAWS and CnID.

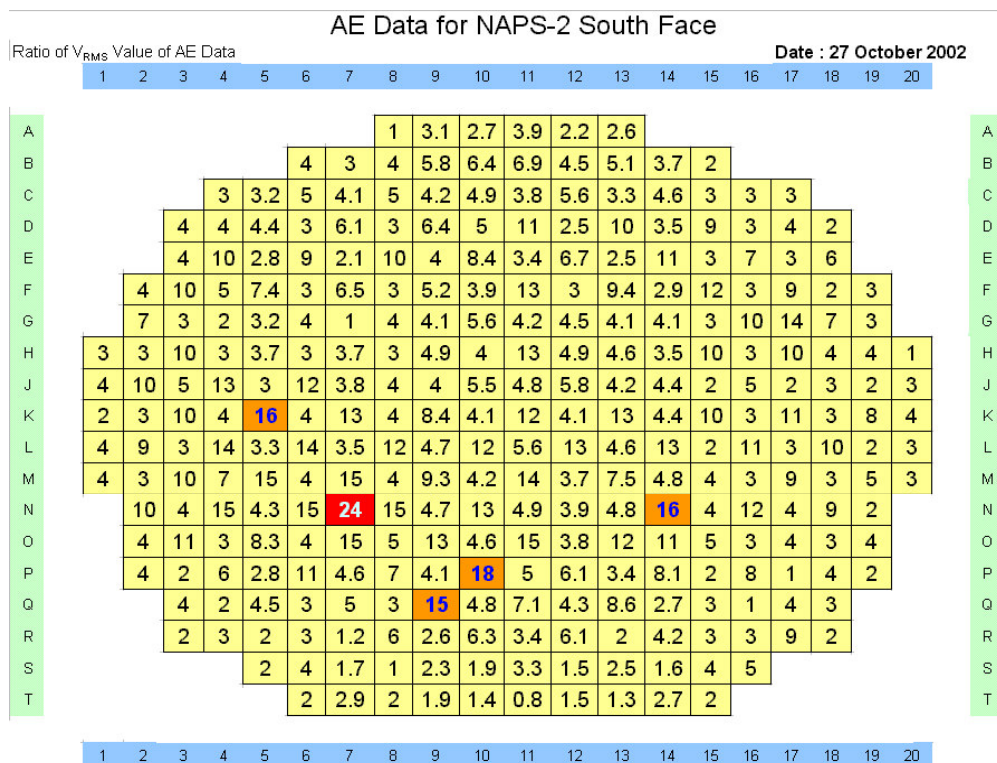

Fig. 14 Distribution of D₂O Leakages in the seal plugs for all 306 fuel channels in gm/cc

Table : AEA System compared with the recently announced DiSP AE system of PAC, USA

Heart of the System	AEDAQ card	PCIDSP-4 card
Bus Architecture	Open architecture PCI/CompactPCI designs with standard form factor for greater modularity and expandability.	PCI with PAC's proprietary system chassis for higher number of channels.
Digital Signal Processor	High performance 32 bit, Floating point SHARC ADSP21062 with 80MFLOPS sustained performance.	DSP with 60 MFLOPS performance
Field Programmable Gate Array	50K Xilinx Spartan IIE devices for Real Time AE parameter extraction.	Multiple FPGAs and ASIC Ics to provide better performance
Hit Detection Capacity	Guarantee of "No Loss" of Hits.	Specifies only maximum number of hits/sec
Software Capabilities	Windows based Modular Software Design with Time and Frequency domain analysis, Multiple Graph Plotting, Offline Parametric Filtering with ANN Tools and 2D/3D location algorithms.	AEWIN software with transient waveform capture, spectral analysis tools and 2D/3D location algorithm
Customization and Expandability	Easy customization and expansion	No Source Code listing is provided

Crack growth and initiation studies on reactor piping components

Acoustic Emission Technique is particularly useful compared to other methods for monitoring crack growth rate as it can be used for online monitoring of growing cracks in operating plant. This helps in pursuing residual life estimation and life extension of PHWRs and heavy water plant components. No of experiments were performed on CT, TT and Three Point bend specimens to study crack initiation and growth at MSD lab Hall-4. Experiments on TT samples showed some AE activity during yielding under monotonic loading. Some of the experiments on Three-point bend Specimens have detected the initiation under fatigue loading. This application was developed jointly by RSD, AFD , MSD and CnID.

Post processing of AE data using artificial neural networks

GUI based ANN simulator has been developed in collaboration with IIT Kanpur, which incorporates many features viz. Clustering algorithms (K-Mean, Self organizing map, Fuzzy clustering method, Gustafsson-Kessel, Rule base clustering system etc), First order algorithm, Second order algorithm, Higher order algorithm, Self-Growing Networks, Fuzzy Neural Networks, Global optimization technique, Bayesian probability techniques & Decision tree algorithm. An additional software module has been developed for the analysis of AE data, which extracts waveform parameters viz. Standard Deviation, Skewness Coefficient, Kurtosis coefficient, Coefficient of variation, Rise Time, Fall Time,

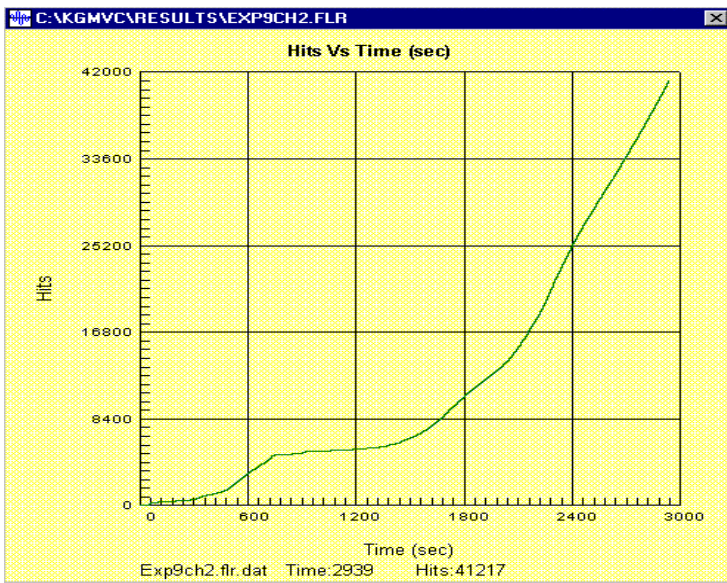

Fig. 15 Hits vs Time graph showing initiation at around 1600 secs

Pulse width, Pulse ratio of the second largest pulses, Partial Power in different frequency bands, Ratio of two largest partial powers, Frequency, RDC etc. These waveform parameters were used to feed information to ANN for continuous type of AE data classification; similarly AE parameters were used for the Burst type of AE data. This simulator was used to filter out noise and extract weak AE signals.



Fig. 16 AEDAQ Photograph

Classification of AE data to detect leaky seal plugs in operating PHWRs

All the 306 coolant channel seal plugs were scanned at full reactor power for probable leakage of D₂O in a predetermined sequential

manner. AE data collected from seal plugs was of continuous type, for these, waveform parameters extracted, were used to feed information to the ANN for their classification. Leaky seal plugs were detected successfully. With this encouraging result it has been planned to perform similar experiment in other PHWRs to establish this technique.

Classification of AE data to detect crack initiation and growth

The ANN software has also been used to filter out Noise from AE data collected from experiments on three point bend specimens to study Crack initiation and propagation at MSD lab Hall-4. As the AE signal in this case is of burst type, AE parameters such as RDC, Peak Amplitude, Rise Time, Duration, RMS and Energy are used. AE data was classified successfully in to five classes in which one class was having 98 % crack initiation data and other classes showing different type of noise patterns.

Conclusion

Multi-Channel Acoustic Emission System (AEA) is first of its kind designed and developed in India, which is an outcome of sustained R & D efforts of the development group. Efforts have been taken to include latest available technologies to make the system at par with international standards. Restricted availability of commercial AE systems and the developer's proprietary system design, which disallows the user to fine tune the system as per his requirement, provided the motivation to design and develop indigenous AEA system. The significant achievement of this effort is the development of a system with open architecture and design experience gained, which would facilitate channel expansion, portability, customization and compactness.

CALCIUM IODATE – ANOTHER EFFECTIVE BLOCKER OF RADIO-IODINE UPTAKE BY THE THYROID GLAND

D.N. Pahuja¹, V.S. Jagtap², V.R. Sonawane², M.G.R. Rajan and A.M. Samuel³

Laboratory. Nuclear Medicine Section, Isotope Group, BARC

Radiation and radioactive substances are the natural features of the environment. They have found wide spread applications in many fields such as: health-care, agriculture industry, power generation, etc, since the advent of this century. This has also increased the chances of the accidental release of radioactivity in the atmosphere, posing an occupational hazard not only to the workers but also to the people around nuclear facilities. Besides this, the atmospheric testing of the nuclear weapons and the nuclear reactor accidents has further added to this danger due to the release of large amounts of radioactivity in the environment. Although there may have been reports on nuclear accidents, the Chernobyl accident, has, for the first time, provided the unique opportunity to study in large cohorts the effects of ionizing radiation over a wide range of dose levels spread over a wide area. Radioactivity levels due to the radionuclides released in the atmosphere because of Nuclear weapons testing and Chernobyl accident is shown below:

Table: 1 Radioactivity due to nuclear weapons tests
[Ref : UNACEAR 2000]

Radionuclides	Activity (Bq)
¹³¹ I	10 ²¹
¹³⁷ Cs	10 ¹⁸
⁹⁰ Sr	10 ¹⁰

It is possible to minimise the exposure due to external irradiation by shifting and resheltering the affected population to the safer distance from the site of the nuclear accident but the danger of continuous radiation – exposure due to *in vivo* deposited radionuclides persist for a long time.

Table: 2 Radioactivity released from Chernobyl accident
[Ref : IAEA-TECDOC-1240]

Radionuclides	Activity (PBq)
¹³¹ I	1700
¹³⁷ Cs	85
¹³⁴ Cs	44
⁹⁰ Sr	8

The radiation exposures [1] may result in the following :

1. Increasing trends of thyroid cancer and severe mental retardations in the younger people due to their exposure to radioiodine (*I) in the initial stages of the accident.
2. Continuous internal exposure to radionuclides ¹³⁷Cs & ⁹⁰Sr, which have deposited around a wide area; entering both live stock and humans through food chain.
3. High infant mortality.
4. High pre-term birth rate.
5. Deaths due to leukemia and haematological disorders and bone cancers may rise by around 50%

It is, therefore, important to take some necessary counter measures to curtail radiation induced damage due to *in vivo* contamination with radionuclides. We have made some important moves in this direction by the development of new, better and more convenient agents for the curtailment of two hazardous radio-nuclides, *Cs and *Sr from the *in vivo* system. Present study is a move in examining the efficacy of another iodine rich compound – Calcium Iodate [Ca(IO₃)₂], which could also serve as one of the promising blocker of radio-iodine uptake by the thyroid gland.

¹Principal Investigator, ²Research Fellow (AERB-Project), ³Former Director, Biomedical Group, BARC

Protocol

Chemicals: *I as $Na^{131}I$ (carrier free), obtained from Board of Radio-Isotope Technology, Thurbhe Complex, Vashi, New Mumbai, as a sterile aqueous solution, was suitably diluted with physiological saline prior to administration. All the chemicals used were of analytical grade purchased from S.D. Fine Chemicals, Mumbai.

Animals: Age and weight matched Wistar rats (350–370g)*, housed individually, were administered *I (~40 KBq/rat). The rats were then divided into 3 groups: Control and two experimental groups – KIO_3 and $[Ca(IO_3)_2]$, each with 5–6 animals/group. Stable iodide (equivalent to ~100mg stable iodide/d/70Kg adult) in the form of KIO_3 (258 μ g/d/100g BW) and $Ca(IO_3)_2$ (240 μ g/d/100g BW) was given separately to each animal, either mixed with diet, orally or

intraperitoneally (ip), 2h after *I -administration. All the animals were monitored for whole body retention (WBR) of *I , 24h later for 9–14d. Some of the animals were examined for bio-distribution of *I [2]. Principles of Laboratory Animal Care (NIH – Publ. No: 86-23, revised, 1995) and the Resolutions of Institutional Animal Ethics Committee were followed in conducting animal studies.

Results

Both KIO_3 and $Ca(IO_3)_2$, whether administered orally or ip, are seen to be equipotent in preventing the uptake of *I by the thyroid gland (Table 3). This is also evident from Table 4 showing the efficacy of KIO_3 and $Ca(IO_3)_2$ in retarding the WBR of *I .

Table 3 : Percent ^{131}I -24h post i.p. (a) and post oral (b) administrations

Tissues	Control		KIO_3 (2h post ^{131}I)		$Ca(IO_3)_2$ (2h post ^{131}I)	
	(a)	(b)	(a)	(b)	(a)	(b)
Blood	1.6 ± 0.4	0.7 ± 0.05	1.6 ± 0.4	0.6 ± 0.05	1.5 ± 0.1	0.5 ± 0.05
Thyroid	33 ± 1	15 ± 1	10 ± 1	4 ± 0.5	8 ± 1	2 ± 0.5
Liver + Gut	11 ± 0.5	6 ± 0.4	16 ± 1	7 ± 0.5	14 ± 1	6 ± 1
Carcas	21 ± 1	11 ± 0.6	17 ± 2	8 ± 0.5	14 ± 4	8 ± 1
Excreta	34 ± 1	66 ± 8	64 ± 5	81 ± 1	61 ± 3	83 ± 1
WBR	62 ± 2	22 ± 1	40 ± 2	14 ± 3	39 ± 2	14 ± 2

Note : Results are means ± S.D. from 5-6 rats. as percent administered dose

Table 4 : Comparison of KIO_3 with $Ca(IO_3)_2$ on the Whole Body Retention of Radio-Iodine, 2 hours after administration

Days	Control		KIO_3		$Ca(IO_3)_2$	
	(a)	(b)	(a)	(b)	(a)	(b)
1	42±5	42±3	28±3	28±4	32±6	24±3
2	18±2	18±2	12±2	12±2	15±2	12±2
3	17±3	17±5	10±4	10±3	14±4	9±3
4	16±4	16±3	8±2	8±1	12±3	8±2
5	15±2	15±2	7±3	7±2	10±2	7±3
6	15±1	15±3	7±1	7±4	8±4	7±2
7	14±2	14±2	8±2	8±2	7±1	6±3
9	14±1	14±3	6±3	6±2	6±2	4±1
10	13±2	-	3±4	-	4±3	-
11	12±1	-	2±1	-	3±2	-
13	11±2	-	2±2	-	2±1	-
14	9±1	-	1±1	-	2±1	-

Note : Results are Mean ± SD (6-7 animals/gr) as % administered dose

Stable iodide (equivalent to 100mg/70Kg adult per day) in the form of KIO_3 and $Ca(IO_3)_2$ is mixed with diet (a). Oral administration (b) also shows similar trend.

Discussion

Iodine – atomic number 53, is a unique element with 24 isotopes but having only one stable isotope with mass of 127 and about half of the other 23 radio-iodines, occur as fission products. Among them, radio-iodine—¹³¹I contributes an increasingly important portion of the total activity starting at several hours after nuclear fission. The dominant internal exposure after a reactor accident or nuclear weapons test or any incident involving fresh fission products is likely to be ¹³¹I. However, the short-lived radioisotopes, ¹³²I, ¹³³I and ¹³⁵I with half-lives ranging from 52 minutes to 6.7 hours, can contribute significantly if the person is in close proximity to a fresh fission product- release.

¹³¹I has a physical half-life of about 8 days and an effective half-life in humans of about 7.6 days. Besides, radio-iodine (^{*}I) is being increasingly used for diagnostic, therapeutic and research purposes. Hence, any accidental release of ^{*}I in the atmosphere could be quite harmful, not only to the workers but also to the general population, which gets exposed. These risks are exemplified by various nuclear accidents more so by the Chernobyl nuclear accident on April 26, 1986 [3]. There is ~100 fold increase in the thyroid cancers after the Chernobyl accident. 90% of these thyroid cancers are of the papillary type, and in most cases are highly invasive, aggressively spreading both within the thyroid gland and its surrounding tissues, resulting in the increased mortality of children and adolescents [4].

This has necessitated taking extra precautions to prevent any excessive irradiation of the thyroid after an accidental release of ^{*}I. Most of the iodine from accident will be quickly absorbed via inhalation, ingestion or the skin absorption or any combination of these. Inhaled iodine reaches equilibrium with body fluids in about 1h [5]. It is advised that individuals who have had an accidental occupational exposure to ^{*}I, regardless of the route of exposure, should immediately be given a 300mg Potassium Iodide

(KI) tablet, which provides 230mg of stable iodide [6]. Five or six drops of SSKI (Saturated Solution KI–1g/ml) in a glass of water are another convenient means to administer the stable iodide. Daily administration of 300mg KI is advised to be continued for 7 to 14 days. This continuation of the blocking agent is needed to prevent recycling of the ^{*}I.

Pahuja *et al.* [7] has further demonstrated that both Potassium Iodide (KI) and Potassium Iodate (KIO₃) are equipotent and the major proportion of ^{*}I uptake by the thyroid could be curtailed by administering stable iodide (100mg/70Kg BW), immediately or at 2-4h after ^{*}I – release. However, it may not be possible to reach the affected population in this prescribed time of 2-4h, because the event of nuclear accident could be quite disturbing and tension oriented. Besides, the environmental contamination may be prolonged and wide spread depending upon the direction of the wind and general weather conditions prevailing at that time. It was also noted that stable iodide in the form of KI or KIO₃ is effective even at 8h after radio-iodine exposure, when administered twice the normal dosage (KIO₃ – 516µg/100g BW equivalent to 200mg stable iodide/70Kg adult) in comparison to the single dose (KIO₃ – 258µg/100g BW), which did not show appreciable thyroid blocking at that time [7].

Double dose of stable iodide is also found to be quite effective during continuous exposure to ^{*}I, in preventing further rise in ¹³¹I–uptake by the thyroid even beyond 7 days, and maintaining it at ~20% compared to that in untreated control rats which show significantly increased thyroid uptake of ~40%. Consequently, ^{*}I – excretion is increased in the rats treated with KIO₃ compared to that in the untreated control rats.

It is, however, necessary that stable iodide should be available in easy and convenient dispensable form preferably as a tablet, which is within the easy reach of the people working near the nuclear facility. KI, however, cannot be stored for a long time because it is quite

hygroscopic and starts losing its iodine. This will require periodic replacement of the older stocks of KI because of its poor shelf life compared to KIO_3 . This aspect is important, considering the need for the real emergency preparedness with stable iodine.

$[Ca(IO_3)_2]$ - another promising radioiodine - blocker, has been used in agriculture - feeds and as a dough - conditioner. It is also more stable than both KI and KIO_3 . It was therefore felt to examine the thyroid blocking efficacy of $[Ca(IO_3)_2]$, and compare with KIO_3 . We observed that both KIO_3 and $Ca(IO_3)_2$, when administered i.p. or orally were found to be equally effective in blocking *I -uptake by the thyroid. Calcium iodate also acts as a source of two important nutritional elements. It provides not only stable iodide which is useful for blocking *I - uptake but also gives calcium, an important bone - mineral, which also helps in preventing absorption of *Sr . It is also shown to preserve cell membrane integrity and modulator of antioxidant defence system by stabilizing/protecting Tocopherol, Glutathione and Protein-thiols - the important scavengers of free radicals normally produced due to radiation-effect .

The results of the present study provide us good evidence that $[Ca(IO_3)_2]$ can serve as another promising radio-iodine blocker which is as equipotent as KI/ KIO_3 in protecting the thyroid gland.

References

1. Proc. International Conference Vienna, One decade after Chernobyl: Summing up the consequences of the accident, 8-12 April, 1996.
2. Pahuja DN, Rajan MGR, Borkar AV, Samuel AM. A simple method to monitor in vivo radioiodine uptake by the rat thyroid in live rats. Demonstration of Potassium Iodate as a thyroid blocker. Bulletin of Radiation Protection 18: 51, 1995
3. Malone, J Unger, J., Delange, F., Lagasse, R., Dumont, J.E, Thyroid consequences of Chernobyl accident in the countries the European community. J. Endocrinol. Invest 14:701-717, 1991
4. WHO — Report (1996): Health Consequences of the Chernobyl Accident. Geneva Scientific Report.
5. Ramsden, D., Passant F.H., Peabody, C.O., Speight, R.G. Radioiodine uptakes in the thyroid. Studies of the blocking and subsequent recovery of the gland following the administration of stable iodine. Health Phys.13:633-646, 1967.
6. Adams, C.A., Bonnell, IA. Administration of stable iodide as a means of reducing thyroid irradiation resulting from inhalation of radioactive iodine. Health Phys. 7:127-149; 1962.
7. Pahuja DN, Rajan MGR, Borkar AV, Samuel AM. Potassium iodate and its comparison to Potassium iodide as a blocker of ^{131}I uptake by the thyroid in rats. Health Physics 65: 545-549, 1993.

FARMERS' RALLIES ON TROMBAY GROUNDNUT VARIETIES

Breeder seed multiplication of the most popular Trombay groundnut variety, TAG-24, was arranged on more than 20 hectares by University of Agricultural Sciences (UAS), Dharwad, during summer, 2003 at Bhoj village, Belgaum Dist. in Karnataka. In this connection, UAS organised a Farmers' Rally on April 6, 2003. The farmers have grown TAG 24 with improved agronomic practices in this sugarcane belt under the banner "Shashwat Krishi Vigyan Kendra" set up by Dr Hemant Kulkarni, the driving force behind the farmers in the village. About twenty scientists from BARC, Trombay, UAS, Dharwad and Tamil Nadu Agricultural University, Coimbatore, and



Farmers' rally at Bhoj village

over 500 farmers participated. Among them were Dr S.A. Patil, Vice Chancellor, Dr B.S. Nadagoudar, Director of Extension, Dr R.R. Hanchinal, Special Officer (Seeds) from UAS, and, Dr K.B. Sainis, Associate Director, Bio-Science Group, Dr S.F. D'Souza, Head, Nuclear Agriculture & Biotechnology Division and scientists associated with Trombay groundnut programme, from BARC. The scientists visited various farmers' fields and studied the performance of TAG-24. This multidimensional team of scientists, farmers and experts discussed under one roof the social, financial, technical and marketing factors in Bhoj village. Dr Kulkarni was emphatic to say that TAG-24 was best suited variety for this region and is becoming rapidly popular among the farmers of this region.



Confirmation of record pod yield at Kehal

The team of BARC scientists was impressed by the enthusiasm of farmers and hoped that the

chronic problem of seed multiplication of popular Trombay groundnut varieties could be resolved only with such a group activity and expressed all support for the success of the project. Officials from Seed Unit, UAS, Dharwad harvested more than 500 quintals of TAG-24 (breeder seed) during summer 2003 which would be entering into seed multiplication chain with various agencies.



Field view of TAG 24 at Bhoj

Kisan Mela on summer groundnut for Trombay groundnut varieties, TAG 24 and TG 26, was also organised by Mr M.N. Ghuge on May 28, 2003 at Kehal Village, Parbhani Dist. in Maharashtra. Scientists from Marathwada Agricultural University, Parbhani, Aurangabad, Nuclear Agriculture and Biotechnology Division, BARC, Mumbai, Krishi Bhushan Awardee, Aurangabad, Media people and more than 100 farmers attended the Mela. These varieties were raised under high input agro-ecological conditions. Statistical wing of Department of Agriculture, Government of Maharashtra, based on crop cutting surveys, recorded 119.0 and 140.0 quintals of wet pods/ha of TAG 24 and TG 26 respectively, during summer, 2003.

Correspondingly, the final dry pod yields were 73.0 and 80.0 quintals/ha as against 15 quintals of national average.

INCELL AUTOMATED GLASS VIAL SEALING SYSTEM FOR RADIOPHARMACEUTICAL PRODUCTS

Division of Remote Handling & Robotics (DRHR) has developed an Incell Automated System to feed *Rubber bung*, *Aluminium cap* and then seal the glass vial after dispensing the radiopharmaceutical products of high activity.

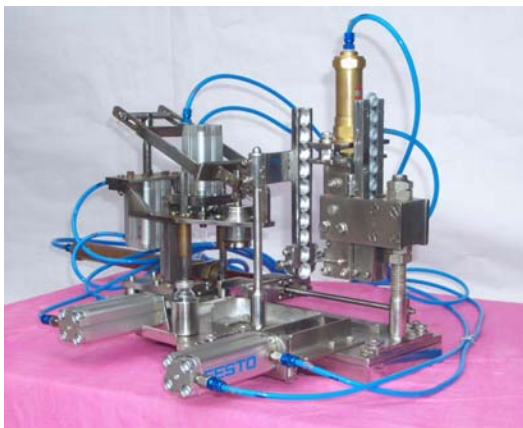

The system operates on compressed air. The

mechanical system is designed in compact modules, so that it can be taken through the transfer port opening and installed inside the cell. The Rubber bungs and Aluminium caps are preloaded in cartridges, transported into the cell and then inserted at respective columns using a tong. Two sizes, 10 & 15-ml vials, can be accommodated in this system. Using the tong, a fresh vial is kept inside a vial-holder and the radio- pharmaceutical product is dispensed. The controller is kept outside the cell. On pressing a button, the vial moves under the rubber plugging station where the rubber bung is plugged and then it is carried to the vial sealing station. On the way, it picks up an Aluminium cap that hangs from a chute. After sealing by the tool, the vial is pushed out for removal. Safety is provided in the design so that no spillage or vial breakage occurs during the entire operation.

This is a major achievement in reducing manual exposure to the workers. At present, this system is installed at BRIT, Vashi complex and similar systems are needed in Radio Pharmaceutical Division (RPhD), BARC. Further development work is under progress to feed the parts using a linear vibratory feeder in place of the cartridges.

TRAINING SCHOOL GRADUATION FUNCTION

The graduation function of OCES2002 (46th Orientation Course for Engineering Graduates & Science Post Graduates), OCEP2003 (12th Orientation Course for Engineering Post Graduates) was held on 28 August, 2003 at the Central Complex Auditorium, BARC.

Dr Arun Nigavekar, Chairman University Grants Commission (UGC), away the Homi Bhabha Gold Medals and delivered the Chief Guests' address.



The Homi Bhabha Awardees with the Chief Guest Dr Arun Nigavekar, Chairman, UGC, Dr Anil Kakodkar, Chairman, AEC & Secretary DAE, and Prof. S.P. Sukhatme, Chairman, AERB

Dr Anil Kakodkar, Chairman, AEC and Secretary, DAE, and Mr Bhattacharjee, Director, BARC, were also present.

A total of 121 OCES2002 and 20 OCEP2003 Trainee Scientific Officers graduated and were inducted into the DAE family. The following is the list of Homi Bhabha Awardees.

Sr.No.	Discipline	Name
1	Mechanical	Mr Santosh Kumar Pradhan
2.	Chemical	Mr Kotak Vimal Kanaiyalal
3.	Metallurgy	Mr Sudipta Mukherjee
4.	Electrical	Mr Anirban De
5.	Instrumentation	Mr Vivek Sheel Mittal
6.	Electronics	Mr Asif Iqbal
7.	Computer	Mr Kumar Vaibhav
8.	Physics	Mr K.V. Shanavas
9.	Chemistry	Ms Teena Goel
10.	Bioscience	Ms Swathi Kota
11.	Environmental Science	Mr Nadar Yesuraja Victor
12.	M.Tech.	Mr Vijay Chaudhry

"परमाणु ऊर्जा विभाग- स्वर्ण जयंती वर्ष" के उपलक्ष्य में सांस्कृतिक कार्यक्रम का आयोजन

परमाणु ऊर्जा विभाग के स्वर्ण जयंती वर्ष में प्रवेश करने के उपलक्ष्य में भाभा परमाणु अनुसंधान केंद्र में राजभाषा हिंदी के प्रचार-प्रसार में सतत प्रयत्नशील संस्था "केंद्रीय सचिवालय हिंदी परिषद् " द्वारा 21/08/03 को एक सांस्कृतिक कार्यक्रम का आयोजन किया गया।

इस अवसर पर परमाणु ऊर्जा आयोग के अध्यक्ष डॉ. अनिल काकोडकर विशेष अतिथि के रूप में तथा केंद्र के निदेशक डॉ. बी. भट्टाचारजी मुख्य अतिथि के रूप में उपस्थित थे। केंद्र के नियंत्रक श्री अँन्टोनी डि'सा, आंतरिक वित्तीय सलाहकार डॉ.जी.डी. पुंगले, कार्मिक प्रभाग के अध्यक्ष श्री नवल किशोर नागर, तथा अन्य वरिष्ठ अधिकारियों एवं सहकर्मियों की उपस्थिति से केंद्रीय सभागृह पूरी तरह भरा



हुआ था। इस अवसर पर केंद्र के कलाकारों ने गीत, संगीत, नृत्य एवं वैज्ञानिक परिचर्चा के माध्यम से अपनी प्रतिभा प्रदर्शित करते हुए श्रोताओं को भारतीय परमाणु ऊर्जा कार्यक्रम की विकास यात्रा से अवगत कराया।

कार्यक्रम की अध्यक्षता पदार्थ वर्ग के निदेशक एवं केंद्रीय सचिवालय हिंदी परिषद् के अध्यक्ष डॉ.श्रीकुमार बॅनर्जी ने की। इस कार्यक्रम का संचालन श्री विजय कदम ने श्रीमती नम्रता कदम तथा परिषद् के अन्य सदस्यों की सहायता से किया।

DAE AND CERN - A COLLABORATION

The Department of Atomic Energy and the European Organisation for Nuclear Research (CERN) have recently collaborated on software development for Large Hadron Collider (LHC). Dr G. Govindarajan, Director, Electronics and Instrumentation Group, BARC, and Hans Hoffman, CERN's Director for Technology Transfer and Scientific Computing, representing the two organisations, signed an addendum to a cooperation agreement for HHC computing.



Dr G. Govindarajan (left), Director, Electronics and Instrumentation Group, BARC, and Hans Hoffmann, CERN's Director for Technology Transfer and Scientific Computing, sign an addendum to a co-operation agreement between CERN and India's Department of Atomic Energy that defines collaboration on software development for LHC computing

CERN is open to qualified scientists from all over the world and, beyond its 20 European member states, has co-operation agreements from 30 countries. Prominent among these – beyond North America and Japan – are India, China, Iran, Brazil, Russia, Mexico, Pakistan, Morocco and S. Africa.

India and Russia, besides participating in experiments have contributed to the construction of accelerators and the LHC at CERN. Due to the internet and to CERN's World Wide Web (www) in particular, Indian particle physicists were the first to make remote collaboration common and have been able to access Large Electron Proton Collider (LEP) data and scientific information

from around the world through the Web while sitting at their desks.

AWARENESS PROGRAMME IN 'RADIOLOGICAL AND INDUSTRIAL SAFETY'

Atomic Fuels Division (AFD), BARC, with Radiation Safety Systems Division (RSSD), BARC, jointly conducted a training course on 'Awareness Programme in Radiological and Industrial Safety' at B - Block Auditorium, Modular Labs during April 28-30, 2003 for the benefit of Tradesmen working at AFD. Along with English, Marathi & Hindi were also used in giving lectures.

Mr R.P. Singh, Head, AFD, BARC, welcomed the Chief Guest Mr D.S. Shukla, Chairman, MOSC and Director, Chemical Engineering and Technology Group, BARC, and participants. He said the safe working practices should become part of habit. This culture will benefit the individual and plant and requested to take maximum benefit from this programme. Mr D.S. Shukla, in his inaugural address, said the safety practices come from engineering design and administrative controls.

Dr D.N. Sharma, Head, RSSD, BARC, said that the awareness programme will improve their consciousness about safety. Recent courses conducted by BARC Safety Council had generated good response from staff members of BARC.

Twenty-six participants from AFD attended the course. The faculty included Mr S.P. Singh, Mr D.V. Venkata Rao, Mr S.D. Bharambe, Mr S.B. Vedak, Mr S.B. Dhani, Dr P.R. Sangurdekar, Dr. Pushparaja, Mr P.B. Sawant and Mr R Rangarajan. The course consisted of 11 lectures and a workshop and demonstration of Health Physics instruments. The lectures covered the

aspect of operational procedures at AFD, industrial safety, chemical safety, radioactivity measurement. instruments, radiation protection standards, health physics surveillance in fuel fabrication and unusual incidents at AFD. Mr H.S. Kamath, Director, Nuclear Fuels Group, BARC, in his concluding remarks, said that such programme will help to improve the safety records in nuclear fuel cycle activities. He appreciated the efforts put in conducting the programme and hoped that many such programmes will be arranged in future. Mr N. G. Dutta, Member Secretary, AFD Safety Committee, proposed vote of thanks.

FIRE SERVICE WEEK – 2003

As an annual feature of observing Fire Service Week, during April 14-20, 2003 Fire Service Week was observed this year too. The observance of Fire Service Week began by observing April 14, 2003 as the "National Fire Service Day", in memory of those fire service personnel who displayed courage and exemplary devotion to duty as they laid down their lives fighting the fire that had erupted on S.S. Fort Sticken in the year 1944 at Mumbai Port Trust Dock and to those brave fire fighters who lost their lives while discharging their duties.



Mr Bhattacharjee, Director, BARC, inaugurating the fund raising campaign for Fire Service Personnel Welfare. Mr A.K. Tandle, C.F.O, BARC, offered a pin flag to Director, BARC.

As a mark of respect to those firemen, the week began with COMMEMORATION DAY being observed on April 14, 2003 by placing a wreath at the memorial.

The fund raising campaign towards Fire Service Personnel Welfare Fund was inaugurated by Mr B. Bhattacharjee, Director, BARC. The pin flag was offered to Director, BARC. On April 16, 2003, the occasion was also graced by Dr S. Banerjee, Director, Materials Group, BARC, and Chairman CFSRC, Mr D.S. Shukla, Associate Director, Chemical Engineering & Technology Group, BARC, and Mr S.K. Ghosh, Head, Chemical Engineering Division, BARC, who were also offered pin flags on this occasion.



Fire Fighting Staff of BARC demonstrating their skill with special emphasis on rescue Techniques using rope at Modular Labs.

As a part of organising various programmes towards increasing general awareness about fire safety, an Exhibition of Fire Safety Equipments, display of Fire Safety Posters at Modular Lab. "C" Block and demonstration on use of fire safety equipment and rescue methods was organised which was witnessed by members of the staff. The Exhibition was inaugurated by Dr V. Venkatraj, Director, Health, Safety & Environment Group, BARC and Chairman, BARC Safety Council.

On April 17, 2003, two crews of Fire Services Section participated in Tactical Medley Drill Competition-2003 &

Individual Ladder Drill Competition-2003 organised by Government of Maharashtra at Cross Maidan, Dhobi Talao, Mumbai. In the Individual Ladder Drill Competition event, second prize comprising of Merit Certificate and cash prize of Rs.300/- was won by Mr M.E. Bhosale, Fireman (B).

As a step towards increasing awareness of fire safety and the role of Fire Services Section in this regard amongst the staff members and their families residing within the vicinity of Anushaktinagar, a demonstration was organised with special emphasis on high rise building safety and use of fire fighting equipment at Akashdeep and Akashratna buildings at Anushaktinagar on April 19, 2003. An overwhelming response was received from the residents of Anushaktinagar.

On April 20, 2003, the Fire Service Week was concluded by participating in final ceremonial parade at Cross Maidan, Dhobi Talao, Mumbai.

NATIONAL WORKSHOP ON RADIOCHEMISTRY AND APPLICATIONS OF RADIOISOTOPES

The 50th BRNS-IANCAS National Workshop on Radiochemistry and Applications of Radioisotopes was held during April 29-May 7, 2003 at H.N.B. Garhwal University, Srinagar, Uttaranchal.

The Workshop was inaugurated by Retd. Air Vice Marshal Dr N. Natarajan, Hon'ble Vice Chancellor, H.N.B. Garhwal University, Srinagar, who presided over the function. Prof. M.S.M. Rawat, Director of the Workshop, welcomed the guests. Coordinator of the Workshop, Dr B.S. Tomar, presented the objectives of the workshop, namely, to encourage the research scientists in the universities and other non-DAE institutes to use radioisotopes in their field of research and to popularise the subject of Nuclear and Radiochemistry among the teaching faculty.



Inauguration of the 50th BRNS-IANCAS National Workshop on Radiochemistry and Applications of Radioisotopes

This will help them to spread the message of the peaceful uses of atomic energy among the masses. This would allay the fears of radioactivity from the mind set of the public. Prof. R.P. Gaur, Dean, faculty of Science, in his address, highlighted the important role of isotopes in DNA sequencing and understanding biochemical reactions. Dr V. Venugopal, Head, Fuel Chemistry Division, BARC and President, IANCAS, was the chief guest of the function and delivered the key note address on Atomic Energy Programme in India. He stressed the need for nuclear energy in India in view of the dwindling as well as low quality of fossil fuel reserves. Hon'ble Vice Chancellor, in his inaugural address, mentioned about the highly knowledgeable faculty of the Garhwal University and students who are quite eager to learn the subjects. He asked for frequent exchange of academic interests between DAE and universities. He asked the teachers, whom he described as the interface between the research workers and the public to spread the message of the resource persons to the masses. He suggested excursion tour of students to the DAE facilities and active collaboration in areas, like Forestry, Horticulture, Water management, etc. He asked Prof. Gaur and Prof. Rawat to form a standing committee which will interact with their counterparts in BARC for future academic exchanges.

The eight-day Workshop was attended by 37 participants from different universities and colleges in and around Uttaranchal. The participants were from different disciplines, such as, chemistry, physics, biology, geology, pharmacy and agricultural sciences. Most of the participants. Prof. A.N. Garg, I.I.T. Roorkee, delivered the lecture on nuclear analytical

participants were college teachers of undergraduate and postgraduate colleges and universities with a few research students. The Workshop was received very well by the participants as evident from the nearly 100% attendance on all the days of the Workshop. The participants took keen interest in the practicals.



Dr V. Venugopal, Head, Fuel Chemistry Division, BARC and President, IANCAS, delivering a lecture to the participants of the workshop.

Dr V. Venugopal, delivered a lecture on the principles of Nuclear Reactors. Prof. Satya Prakash, Dean, faculty of Science, Dayalbagh Educational Institute(DEI), Agra, delivered two lectures, one on the nuclear structure and stability and other on applications of radioisotopes in agriculture. He presented some of the work carried out in his laboratory on chromium uptake by plants. Dr B.S.Tomar, BARC, delivered three lectures on radioactivity and nuclear decay, radiation detection & measurement, and production of radioisotopes. Dr R.M.Sawant, BARC, delivered two lectures on Introduction to practicals and applications of radioisotopes in chemistry. Dr Rani Gnanasekar from BRIT, DAE, delivered the lecture on application of radioisotopes in medicine. Mr Arunashis Bhattacharya, BARC, gave the lecture on radiation chemistry. Dr S.Murali's (BARC) lecture on health physics aspects and Dr S.K.Sali's (BARC) lecture on setting up of a radiochemical laboratory generated a lot of interest among the techniques including their own work on analysis of trace metals in tobacco. Dr R.C. Ramola of

H.N.B. Garhwal University, New Tehri Campus, delivered a lecture on applications of radioisotopes in earth sciences. He also presented some of the results of their work on radon monitoring in Garhwal Himalayas. Dr S. Sabharwal, Head, RTDS, BARC delivered a lecture on radioisotopes and radiations in industry, with emphasis on radiation induced polymerisation and its applications. Dr G.R. Relhan, Programme Officer, BRNS, in his lecture gave an account of the various BRNS activities.

Dr S. Sabharwal, Head, RTDS, BARC, was the chief guest for the valedictory function. Prof. Geeta Joshi welcomed the gathering. Dr B.S. Tomar presented the highlights of the Workshop, while Prof. M.S.M. Rawat gave a detailed account of the activities during the

Workshop. Dr Sabharwal, in his address, appreciated the efforts made by the Garhwal University in organising the Workshop despite the scarce resources. He said that the success of the Workshop will be decided by the fact how many participants will ultimately start using radioisotopes and radiations in their field of research. He later gave away the certificates to the participants. Subsequently, the coordinator of the workshop handed over the set of equipment to the Director of the workshop.

The feed-back received from the participants was excellent.

The workshop was extensively covered by the local press such as *Dainik Jagran* and *Amar Ujala*.

TRAINING COURSE IN BASIC RADIATION PROTECTION

Radiation Safety Systems Division (RSSD), BARC, organised a training course in basic radiation protection for the staff members working in the BRIT Facilities at BARC, Vashi Complex, with support of BRIT. The training course covered 12 lectures on plant specific topics as well as radiation/industrial safety during August 26-29, 2003. A plant visit as well as demonstration on usage of health physics monitoring instruments was also organised. Thirty staff members participated in the course.

Dr J.K. Ghosh, Dy. Chief Executive, BRIT, welcomed the audience and explained to the participants the necessity of the training course. Dr N. Ramamoorthy, Chief Executive, BRIT, in his inaugural address, said that such training programmes would enhance the

safety awareness among the staff. He emphasised that safety should be an integral part of laboratory work procedures. He further added that refresher courses, covering any change in the protection standards, safety procedures/regulations, should be periodically conducted to enlighten the staff-members working with radioactive materials. Dr Pushparaja, Head, RHC Section, RSSD, BARC, explained that keeping in view the regulatory requirements and to familiarise the staffs on the activities going



Dr N. Ramamoorthy, Chief Executive, BRIT releasing the lecture notes. Others on dais are (from left) Dr J. K. Ghosh Dy. Chief Executive, BRIT, Dr Pushparaja, Head, RHCS, RSSD, BARC and Mr. N. Swaminathan, Course Coordinator and OIC, HP unit, BRIT.

on at Vashi Complex, the course was organised in collaboration with BRIT.

The topics covered included principles of radiation protection, radiation units and quantities, biological effects of radiation and plant specific topics such as activities of RPhP & LCO, MBPP, BRIT, health physics surveillance in MBPP, industrial EB accelerators, gamma irradiators, health and safety aspects in accelerators & gamma irradiators, lessons learnt from the incidents in accelerators/ gamma irradiators, industrial hygiene and safety, and transport regulation of radioactive materials.

On the concluding day, a test was conducted to evaluate the effectiveness of the course. This was followed by a feed-back session. The session was chaired by Dr P.S.Iyer, Chairman, BRIT Safety Committee (SCRL), who also distributed the participation certificates. Dr D.N. Sharma, Member-Secretary, BSC and Head, RSSD, in his concluding remarks appreciated the cooperation and support provided by BRIT and suggested that a similar course for staff at operator level should also be conducted for increasing safety awareness.

Mr N. Swaminathan, Course Coordinator and Officer-in-Charge of Health Physics Unit, BRIT, BARC Vashi Complex delivered a vote of thanks.

भा.प.अ. केंद्र के वैज्ञानिकों को सम्मान / BARC SCIENTISTS HONOURED



• श्री ए.के. चौहान, तकनीकी भौतिकी एवं प्रोटोटाइप इंजीनियरिंग प्रभाग, को फरवरी 24-26, 2003 के दौरान अन्ना विश्वविद्यालय चेन्नई में आयोजित क्रिस्टल ग्रोथ पर नववीं राष्ट्रीय गोष्ठी में "आटोमेशन ऑफ जेक्रेलस्की क्रिस्टल ग्रोथ सिस्टमज" पर शोधपत्र की मौखिक प्रस्तुति के लिये

इन्डियन साइन्स कांग्रेस एसोसिएशन की ओर से सर्वश्रेष्ठ शोधपत्र पुरस्कार प्राप्त हुआ।

Mr A.K. Chauhan of Technical Physics & Prototype Engineering Division, BARC, has received the best research paper award of Indian Science Congress Association for the oral presentation of his paper "Automation of Czochralski Crystal Growth System" at the ninth National Seminar on Crystal Growth, held at Anna University, Chennai, during February 24-26, 2003.



• श्री एन.जी. दत्ता, परमाणु ईंधन प्रभाग, भाभा परमाणु अनुसंधान केंद्र को सितंबर 2003 के दौरान मुंबई में आयोजित वार्षिक सामान्य सभा में नान-डिस्ट्रेक्टिव टेस्टिंग मुंबई शाखा के लिए रिसर्च एन्ड डेवेलोपमेंट एनडीटी अचीवमेंट पुरस्कार से सम्मानित किया गया। यह पुरस्कार उन्हें नान- डिस्ट्रेक्टिव टेस्टिंग विशेषकर हीलियम लीक डिटेक्शन टेस्ट सिस्टमज में उल्लेखनीय योगदान को मान्यता देने के लिये प्रदान किया गया। देश में प्रथमतः 350⁰C जैसे उच्च तापमान पर नाभिकीय ईंधन तत्व हीलियम लीक टेस्टिंग की कार्यविधि तथा विकास में श्री दत्ता का उल्लेखनीय योगदान रहा है। पुरस्कार में एक प्रशस्ति-पत्र तथा 5,000 रुपये की राशि निहित है।

Mr N.G. Dutta of Atomic Fuels Division, BARC, was presented the 'Research & Development – NDT Achievement Award' by Indian Society for Nondestructive Testing, Mumbai Chapter, at its Annual General Meeting (AGM) at Mumbai, during September 2003. This award was conferred on him in recognition of his pioneering contributions in the field of non-destructive testing specially in Helium Leak Detection Test systems. A noteworthy contribution made by Mr Dutta is the development of test procedures and experimental facilities for carrying out Helium Leak Testing of nuclear fuel elements at high temperature of around 350°C, a feat performed for the first time in the country. The award consists of a citation and a cash incentive of Rs. 5,000/-

Edited and published by Dr Vijai Kumar, Head, Library & Information Services Division, Bhabha Atomic Research Centre, Trombay, Mumbai 400 085.

Editorial Management : T.C. Balan, Computer graphics & layout : P.A.S. Warriar

BARC Newsletter is also available at URL: <http://www.barc.ernet.in> (for private circulation only)